

Design and Simulation of a New DC Power Supply Based on Dual Bridge Matrix Converter

A. Dastfan*, F. Behrangi*

Abstract: A conventional high power DC power supply systems consist of a three-phase diode rectifier followed by a high frequency converter to supply loads at regulated DC voltage. These rectifiers draw significant harmonic currents from the utility, resulting in poor input power factor. In this paper, a DC power supply based on dual-bridge matrix converter (DBMC) with reduced number of switches is proposed. In the proposed circuit, three switches convert the low frequency AC input to a DC link. A single-phase bridge inverter converts the DC-link to a high frequency AC output. The output of the matrix converter is then processed via a high frequency isolation transformer and rectified to the regulated DC voltage. In the proposed topology only a simple voltage control loop ensures that the output voltage is regulated against load changes as well as input supply variations and the current control loop is not used to correct the input currents. Theory analysis and simulation are made to investigate performance of the proposed circuit. Simulation results show that in the proposed power supply with 7-switch, the input currents are of a high quality under varying load conditions and input voltage.

Keywords: DC power supply, Double-bridge matrix converter, reduced number of switches.

1 Introduction

Following introduction of matrix converter in 1980 by Venturini [1], the hard switching matrix converter (MC) has received considerable attention in recent years as it is a direct frequency conversion device that generates variable magnitude, variable frequency output voltage from the ac utility line. The low volume, the sinusoidal and balanced input current, the bidirectional power flow, and the lack of the bulky and limited-lifetime electrolytic capacitors are the main advantages of the matrix converter over AC-DC-AC converter.

In order to use this converter in the industrial area, many research papers have been published. These papers mainly focus on safe commutation of bidirectional switches, and matrix converter application and its PWM control methods [2]-[4]. However, this converter has not been able to be widely accepted by the industry. The main issue is that it has potential commutation problems requiring a complex control circuit as well as a bipolar snubber to protect against wrong commutation. To overcome these problems the

dual-bridge three-phase to three-phase matrix converter (DBMC) is proposed and used which need less switches and its commutation process is easier [5], [6].

In a conventional DC power supply based on matrix converter with three-phase input as shown in Fig. 1, the power stage includes six bidirectional switches (12 switches) [7]. The operation of this power supply is expressed mathematically in a matrix formation, where the matrix converter switching function is the product of rectifier mode switching function by inverter mode switching function. The low frequency (50 or 60 Hz, three-phase) input is directly converted to high frequency signal by applying the matrix converter switching function to power stage. In the rectifier mode by using a proper switching algorithm, input currents will have a high quality and also a low total harmonic distortion (THD). A symmetrical AC profile is generated at the primary side of the high frequency isolation transformer by applying specific pulses to power switches that these pulses consider the restrictions of the matrix converter. These restrictions are discussed in [4]. In this matrix converter, the implementation of control techniques like space vector modulation (SVM) permits to sinusoidal shape of the input line current waveforms [8], [9].

Iranian Journal of Electrical & Electronic Engineering, 2009.

Paper first received 17 May 2008 and in revised form 29 Dec. 2008.

* The Authors are with the Faculty of Electrical and Robotic Engineering, Shahrood University of Technology, Shahrood, Iran.

E-mail: dastfan@ieeee.org, arashkntu@yahoo.com

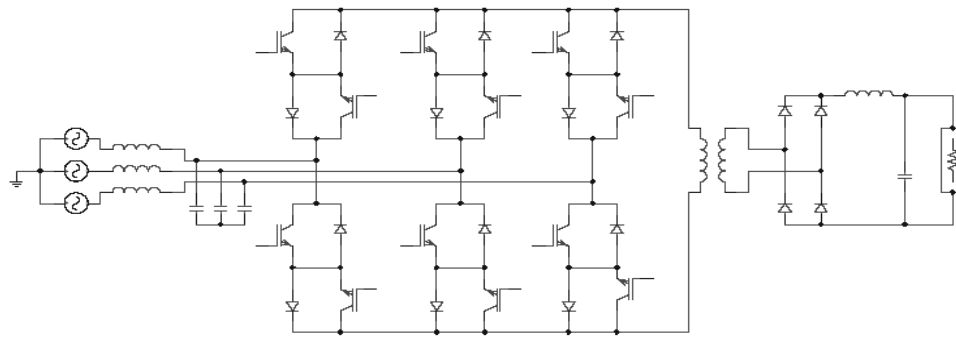

Fig. 1. A conventional DC power supply based on matrix converter

There is another method, which is known as direct control method, for DC power supply that is shown in Fig. 2. This power supply is using matrix converter directly to convert the low frequency input voltage to a DC with applying a low frequency modulation function [10], [11]. Hence, high frequency isolation transformer is not used in this approach.

There are two main drawbacks in these two approaches. Firstly, a large number of switches (12 switches) is needed which lead to the complexity and high cost of the converter. Secondly, two separated control loops are needed, the current control loop is used to correct the input currents and the voltage control loop is used to adjust the output voltage.

In this paper, a DC power supply based on double bridge matrix converter is proposed which the number of switches reduced from twelve switches to seven switches. In addition, the bidirectional switches constructions which have complex commutation and protection problems are not used. The other advantage of the proposed topology is its simple control algorithm compare to complicated control methods used in other DC power supplies based on matrix converter. A detailed analysis of the modulation scheme is given, and

simulation results are provided to verify its feasibility.

2 Proposed Circuit

In the conventional three-phase to one-phase matrix converter, as shown in Fig. 3(a), twelve IGBT switches is employed. The output voltages are obtained by the multiplication of the modulation matrix with the input voltages as given in (1).

$$\begin{aligned} [v_o] &= [M] \times [v_{abc}] \\ [i_{abc}] &= [M]^T \times [i_o] \end{aligned} \quad (1)$$

where v_{abc} is the input three-phase voltage and v_o is the high frequency single-phase output voltage of the matrix converter and M is the modulation matrix as follow:

$$M = \begin{bmatrix} m_{Aa} & m_{Ab} & m_{Ac} \\ m_{Ba} & m_{Bb} & m_{Bc} \end{bmatrix} \quad (2)$$

This basic solution represents a direct transfer function approach and is characterized by the facts that, during each switch sequence time, the average output voltage is equal to the demand (output) voltage. For this

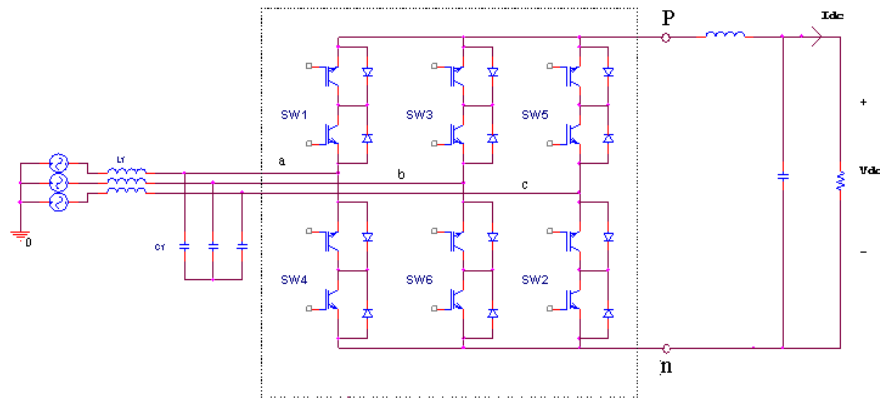

Fig. 2. A DC power supply with direct control method based on matrix converter

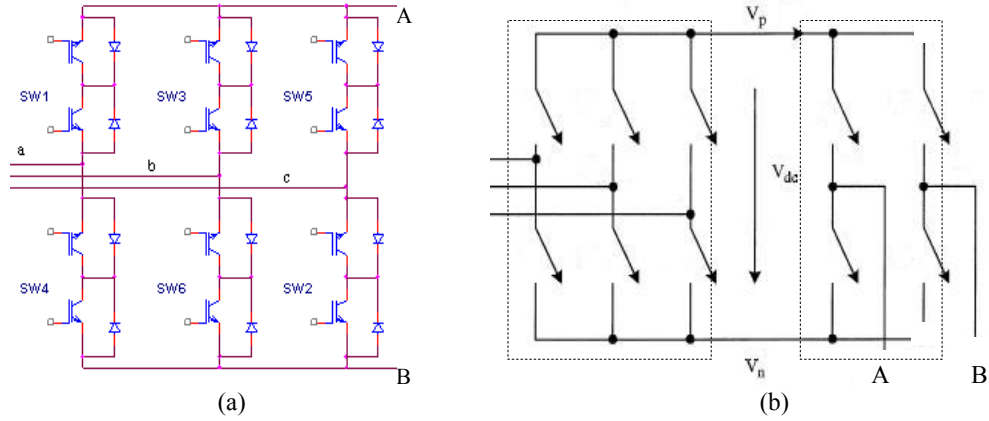

Fig. 3. Three-phase to single-phase matrix converter (a) Conventional circuit (b) Double bridge circuit

to be possible, it is clear that the target voltages must fit within the input voltage envelope for any output frequency. To avoid short-circuit in input side and open-circuit in inductive output terminal, only one bidirectional switch in one output leg must conduct at any time. This constraint can be expressed as:

$$0 \leq m_{ij} \leq 1 \quad j \in \{A, B\} \ \& \ k \in \{a, b, c\} \quad (3)$$

$$\sum_{k=a,b,c} m_{jk} = 1 \quad (4)$$

Under balanced conditions, the three-phase input voltages obey equation (5).

$$V_a + V_b + V_c = 0 \quad (5)$$

Fig. 3(b) shows the matrix converter as an AC-DC-AC conversion system which is known as Dual Bridge Matrix Converter (DBMC) or also known as indirect matrix converter [6]. Thus, Equation (1) can be transformed into two dimensional equations by introducing two additional points (p, n), where:

$$[v_{pn}] = [M_r] \times [v_{abc}] \quad (6)$$

$$[v_o] = [M_i] \times [v_{pn}] \quad (7)$$

where, M_r and M_i represent modulation matrixes of the rectifier and inverter in Fig. 3(b). These equations show that the conventional matrix converter and DBMC are mathematically identical with each other. In equation 4, the bi-directional switches on the load side can be replaced by unidirectional voltage blocking switches if V_p is always greater than V_n . Therefore the inverter part consists of four switches. If the DC link current always be positive, six switches with series diode in three-phase rectifier section are needed which is shown in Fig. 4(a). In [5] it is shown that this rectifier can be replaced with a three-switch circuit as shown in Fig. 4(b).

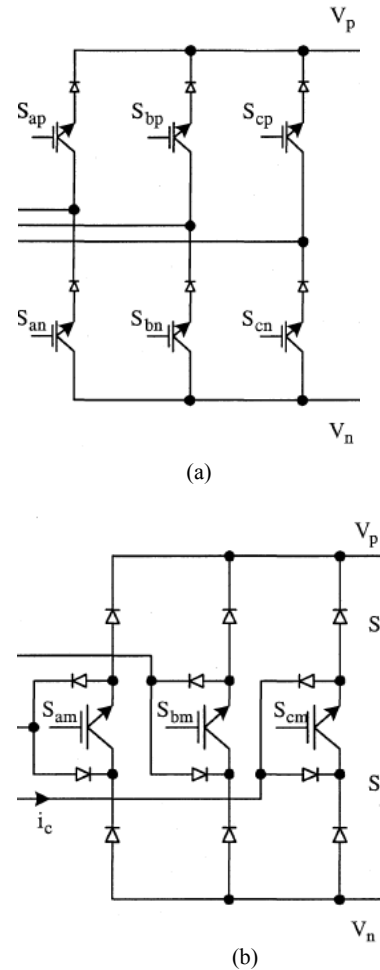

Fig. 4. Rectifier section of the DBMC (a) its six switch configuration (b) its three switch configuration

The complete circuit diagram of the proposed power supply is shown in Fig. 5. In rectifier part, the low frequency (50 or 60 Hz, three-phase) input is converted

to a DC by proper switching of three switches that these switches have specific arrangement of diodes. In inverter part, a single phase bridge inverter converts the DC-link to a high frequency one-phase ac output. The output is then processed via a high frequency isolation transformer and rectified to DC voltage. In the proposed circuit, both the line and load side converter plays the same role as the other topologies (12 switch matrix converter). In that, the line side converter serves as a CSI and the load side converter serves as a VSI. Also, the input/output waveforms and voltage transfer ratio are the same as in the other topologies. This converter has the same characteristics as the 12-switch topology. Since the bi-directional switch is not available in the market by this time, the cost of this converter is expected to be much lower than that of a converter using bi-directional switches. In proposed circuit due to using a diode rectifier after high frequency transformer, the power flow is unidirectional. Therefore, the seven-switch matrix converter topology has been employed as shown in Fig. 5.

3 Proposed PWM Method

3.1 Operation of Rectifier part

In order to simplify the analysis of the rectifier, it is supposed that there is no input filter in the line side. The aim of the pulse width modulation of the rectifier is to maintain positive voltage in the DC side as well as to maintain the input power factor as unity. It is assumed that the input source voltages are described as (8): With in any 60° interval between two successive zero crossing of input phase voltages, as shown in Fig. 6, only one of the three-phase input voltages has the maximum absolute value and the other phase voltages have opposite polarity voltage. For example in the 3rd sector, phase b has the maximum positive value and phase a and c have negative values. Since the input line voltages are balanced, there are two possible conditions for the input phase voltages:

$$\begin{cases} v_a(t) = V_m \cos \theta_a = V_m \cos(\omega_i t) \\ v_b(t) = V_m \cos \theta_b = V_m \cos(\omega_i t - \frac{2\pi}{3}) \\ v_c(t) = V_m \cos \theta_c = V_m \cos(\omega_i t + \frac{2\pi}{3}) \end{cases} \quad (8)$$

a) Two voltages are negative, and one is positive (e.g. sectors 1, 3, and 5). For example in the 3rd sector, phase a and c are negative, phase b is then positive. Therefore:

$$|V_b| = |V_a| + |V_c| \quad (9)$$

Under this condition, switch S_{bn} must be maintained in the conducting state while S_{an} , S_{cn} are modulated. When S_{an} is turned on, the DC voltage is equals to V_{ba} and is positive. The duty ratio of switch S_{an} is given by

$$d_{ab} = \frac{|\cos \theta_a|}{|\cos \theta_b|} \quad (10)$$

While S_{cn} is turned on, the DC voltage equals to V_{bc} and is positive. The duty ratio of S_{cn} is given by:

$$d_{cb} = \frac{|\cos \theta_c|}{|\cos \theta_b|} \quad (11)$$

The average DC side voltage in this switching interval is:

$$V_{dc} = d_{ab}(V_b - V_a) + d_{cb}(V_b - V_c) \quad (12)$$

Substituting (8), (10), and (11) in (12), result:

$$V_{dc} = \frac{3V_m}{2|\cos \theta_b|} \quad (13)$$

b) Two voltages are positive and one is negative (e.g. sectors 2, 4, and 6). For example in sector 6, phase a and c are positive and phase b is negative. One can

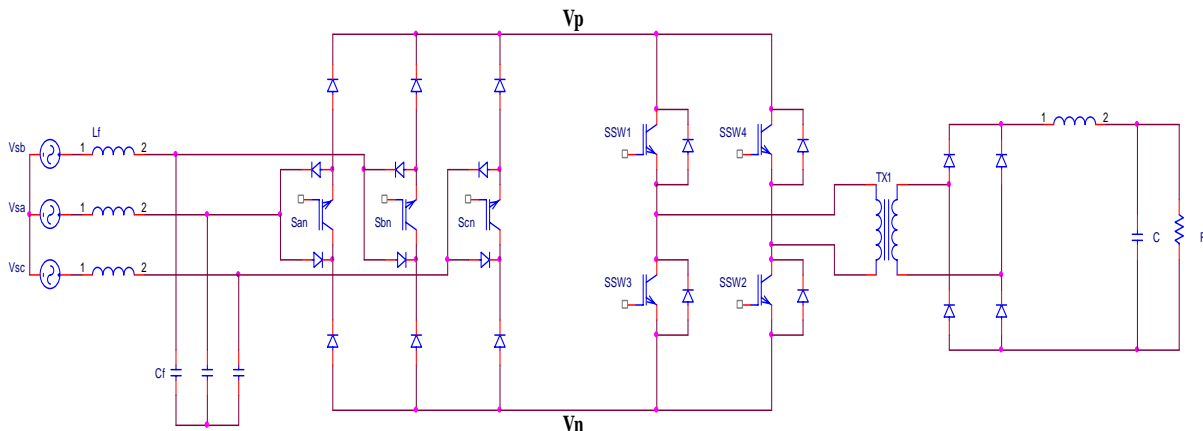

Fig. 5. Proposed power supply with reduced number of switches

establish that:

$$|V_b| = |V_a| + |V_c| \quad (14)$$

Under this condition, switch S_{bn} must be maintained in the conducting state while S_{an} , S_{cn} are modulated. During the time when S_{an} is turned on, the DC voltage equals to V_{ab} and is positive. The duty ratio of S_{an} can be expressed as:

$$d_{ab} = \frac{|\cos \theta_a|}{|\cos \theta_b|} \quad (15)$$

When S_{cn} is turned on, the DC voltage equals to V_{cb} and is positive. The duty ratio of S_{cn} is:

$$d_{cb} = \frac{|\cos \theta_c|}{|\cos \theta_b|} \quad (16)$$

Finally the average value of the DC voltage during this switching interval is:

$$V_{dc} = d_{ab}(V_a - V_b) + d_{cb}(V_c - V_b) \quad (17)$$

Substituting (8), (15), and (16) in (17), one obtains

$$V_{dc} = \frac{3V_m}{2|\cos \theta_b|} \quad (18)$$

Utilizing the same approach, one can obtain the corresponding duty ratio and switching state for all other sector conditions. Therefore the average value of DC voltage during each of these switching intervals is:

$$V_{dc} = \frac{3V_m}{2 \cos \theta_{\max}} \quad (19)$$

where:

$$\cos \theta_{\max} = \max(|\cos(\theta_a)|, |\cos(\theta_b)|, |\cos(\theta_c)|) \quad (20)$$

Fig. 7 shows the gating signals of the three switches (S_{an} , S_{bn} and S_{cn}) in the six switching intervals based on line side voltages. In order to satisfy unity displacement power factor input current requirement and full utilization of input source voltage, the duty ratios d_a , d_b and d_c should be:

$$d_a = \frac{|\cos(\theta_a)|}{\cos \theta_{\max}}, d_b = \frac{|\cos(\theta_b)|}{\cos \theta_{\max}}, d_c = \frac{|\cos(\theta_c)|}{\cos \theta_{\max}} \quad (21)$$

By using this modulation the input current shape is sinusoidal and in phase with input voltage. The formula found for the DC-link voltage, which is given in (19), is similar to the fictitious DC voltage in a conventional matrix converter when the space vector modulation (SVM) method is utilized for the its rectifier side [9] which is:

$$V_{dc} = 1.5 \times m_c \times V_m \quad (22)$$

where, m_c is the modulation index.

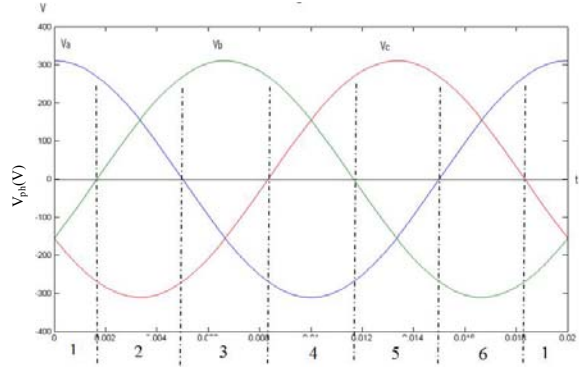

Fig. 6. Six sectors of input phase voltages

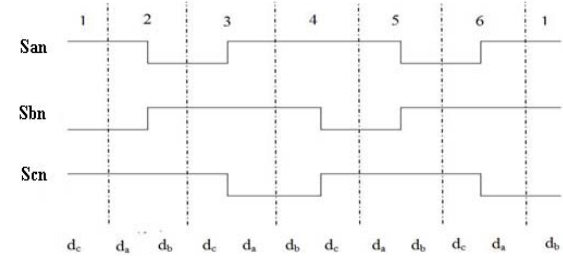

Fig. 7. The gating signals of the three switches (S_{an} , S_{bn} and S_{cn}) in the six switching intervals based on line side voltages

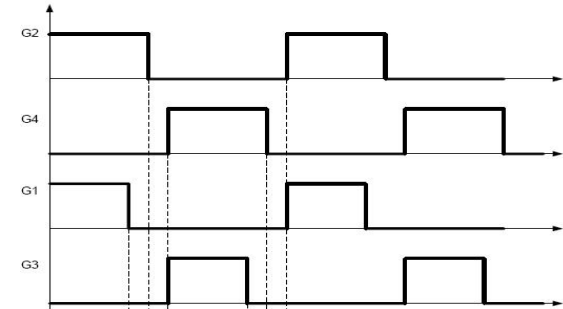

Fig. 8. Gating signals of the inverter switches

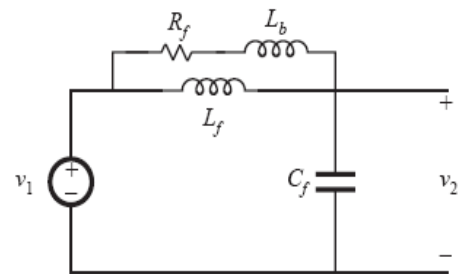

Fig. 9. The input damped single-stage LC filter

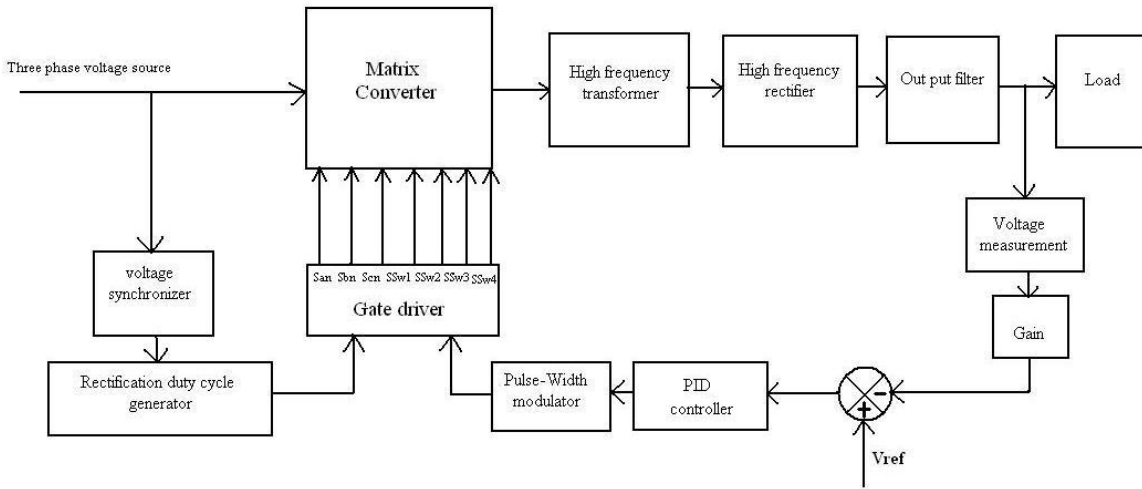

Fig. 10. Block diagram of the control system

3.2 Operation of Inverter part

The objective of using this part is to generate a high frequency single phase output voltage. The operating frequency in this part is the same as desired output frequency which in this simulation is set to 25 KHz. From the rectifier part, DC voltage (V_{pn}) is adjusted and fixed. It is used as the input of single phase inverter. In order to have a constant output voltage, the Pseudo Phase Shift Control (PPSC) algorithm has been used to control four switches.

Gating signals of the inverter part have been shown in Fig. 8. Its operating principle is that the diagonal switches of the full bridge inverter turn on at the same time, and the leading-leg switches turn off earlier than the lagging-leg. The turn on time of the leading-leg is adjustable and the turn on time of the lagging-leg is fixed. So, the output power can be adjusted by changing the turn on time of the leading-leg. Therefore output voltage is regulated by control of only two switches, S_{w1} and S_{w3} .

4 Input and Output Filter Design

The input and output filters form a critical part of the converter system design. The topology of these two filters is shown in Fig. 5. The output filter is a single-stage LC filter ($L = 50 \mu\text{H}$, $C = 500 \mu\text{F}$) and has been designed in conjunction with the output voltage control, using the techniques described in [12].

The input filter is a damped single-stage LC filter with an RL connected in parallel with the inductor to provide damping, especially during turn-on as shown in Fig. 9. The input filter is designed using a decoupled approach. The input filter capacitance is chosen to give a maximum voltage distortion of 5% at the input terminals to the matrix converter. The input inductance is then chosen to give a maximum of 5% current

distortion to the supply. Once the values have been chosen the resonant frequency of the filter is calculated to ensure that it is not close to any of the switching frequency harmonics from the converter. In this circuit, the value of the input filter parameters has been found as follow [12]:

$$\begin{aligned} L_f &= 440 \mu\text{H}, C_f = 20 \mu\text{F} \\ L_b &= 220 \mu\text{H}, R_f = 12.86 \Omega \end{aligned} \quad (23)$$

5 Controller Design

In this section a feedback for this converter is designed to keep the output voltage constant, regardless of changes in the input voltage or in the load. This is accomplished by building a circuit that varies the inverter control input (i.e. the duty cycle D) in such a way that the output voltage is regulated to be equal to the desired reference value. To design the control system, a dynamic model of the switching converter is needed. The block diagram of the feedback system of the proposed circuit is shown in Fig. 10.

The averaged model of the proposed converter after rectifier section, which is like a buck converter, in constant frequency gives the following transfer functions [13], [14].

$$G_{vd}(s) = \frac{V}{D} \frac{1}{1 + \frac{S}{Q\omega_0} + \left(\frac{S}{\omega_0}\right)^2} \quad (24)$$

$$G_{vg}(s) = D \frac{1}{1 + \frac{S}{Q\omega_0} + \left(\frac{S}{\omega_0}\right)^2} \quad (25)$$

where $G_{vd}(s)$ is the control to output transfer function and $G_{vg}(s)$ is the input to output transfer function. A continuous-time PID compensator is designed to give an appropriate loop gain with cross over frequency of $f_c = 5$ kHz and phase margin of $\varphi_m > 60^\circ$, and very high dc gain as given in (26) and (27).

The Magnitude and phase response of this compensator is illustrated in Fig. 11.

$$G_c(s) = G_{pd}(s)G_{pl}(s) = G_{pd0} \frac{\left(1 + \frac{S}{\omega_z}\right)\left(1 + \frac{S}{\omega_L}\right)}{\left(1 + \frac{S}{\omega_p}\right) \frac{1}{\omega_L} S} \quad (26)$$

$$G_c(s) = \frac{(1 + 9.36 \times 10^{-5} S)(1 + 3.2 \times 10^{-4} S)}{(1 + 1.1 \times 10^{-5} S) 1.2 \times 10^{-3} S} \quad (27)$$

6 Simulation Results

In this section, simulation results of the proposed approach are presented and discussed. The system simulations have been done using MATLAB/SIMULINK. The specification of the simulated circuit is given in Table 1.

Fig. 12 and Fig. 13 show the input phase current of I_a and its harmonic spectrum respectively in steady state condition. It is clear that input current is of high quality and its THD is limited to 2.59%.

Fig. 14 shows the high frequency output voltage of the matrix converter (output of the high frequency transformer) and Fig. 15 shows the DC output voltage.

To show dynamic performance of the proposed power supply, simulations have been done for sudden change of the load and input voltage. Fig. 16 shows input current I_a when sudden change of load is happened and Fig. 17 shows output voltage in that case. This is obvious that that after a short time, DC output voltage return to the set point value (48 V).

Table 1. Design specifications of the proposed approach

Design Specification	Values
Input line voltage (v_i)	380 V
Input frequency (f_i)	50 Hz
Switching freq. in rectifier mode	10 KHz
Switching freq. in inverter mode	25 KHz
Output DC Voltage (V_{dc})	48 V
Load power (P_o)	6 KW

To show the effectiveness of the proposed system when the input voltages vary, 15% reduction of the three-phase input source voltages has been applied to the converter. Fig. 18 shows input current I_a due to this input voltage changes and Fig. 19 shows DC output voltage due to this reduction. These figures show that the proposed circuit and algorithm doing well and DC voltage is fixed in the set-point.

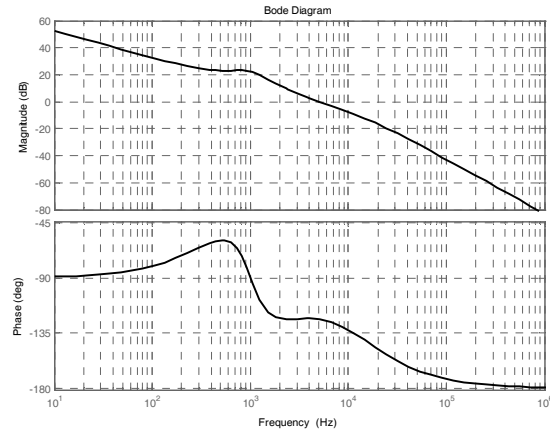

Fig. 11. Magnitude and phase response of the PID compensator

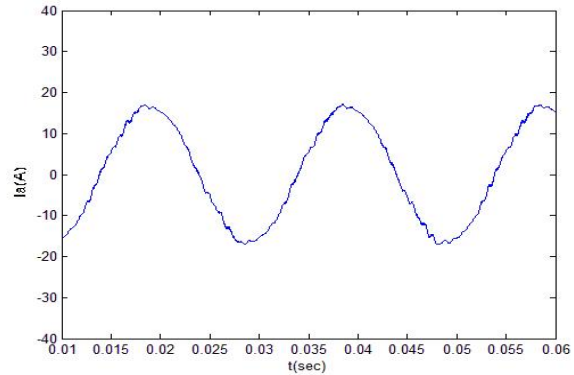

Fig. 12. The input current I_a at 6KW output power

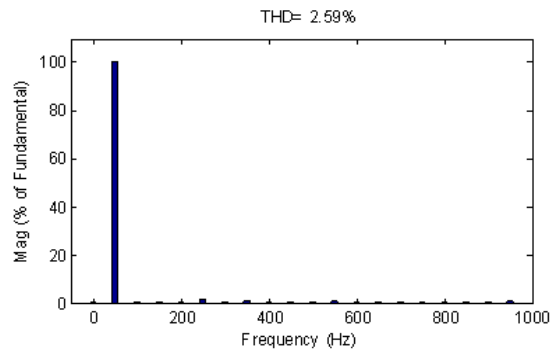

Fig. 13. The input current (I_a) harmonic spectrum

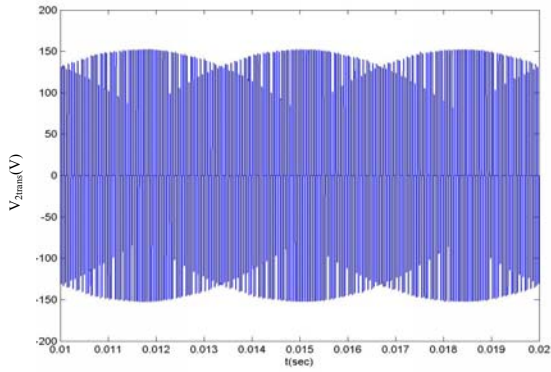

Fig. 14. High frequency output voltage of the matrix converter

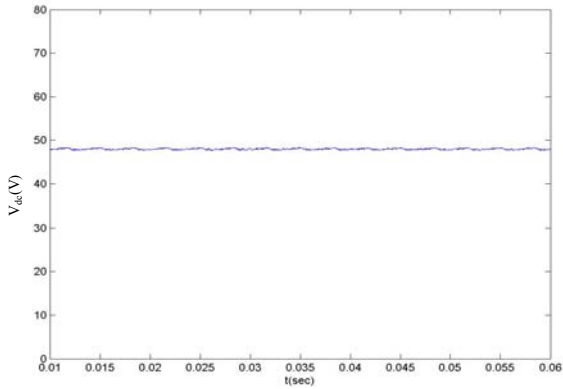

Fig. 15. Output DC voltage

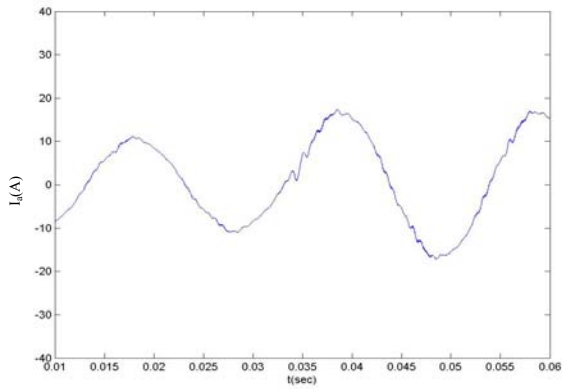

Fig. 16. Input current I_a due to sudden change of the load

7 Conclusion

In this paper a DC power supply based on matrix converter with reduced number of switches has been proposed. In the proposed topology only a simple voltage control loop is proposed and used, which can largely simplify its control complexity and the

bidirectional switches construction which have specific commutation and protection problems are not needed to use. Simulation results verify the feasibility of the proposed converter in steady state and transient conditions.

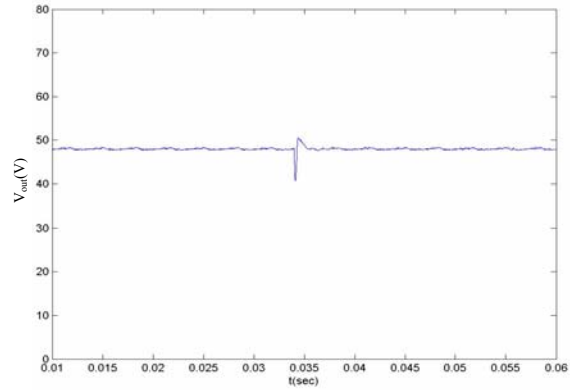

Fig. 17. Output DC voltage due to sudden change of the load

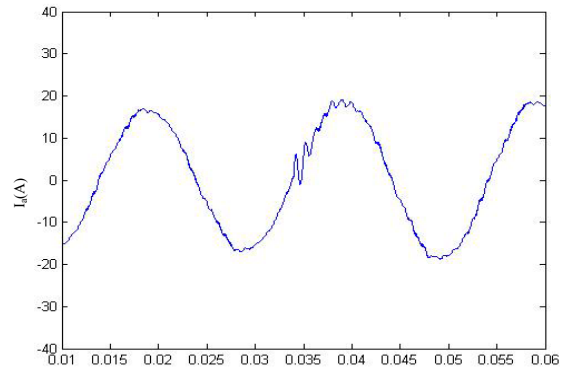

Fig. 18. Input current I_a due to 15% reduction of the input voltages

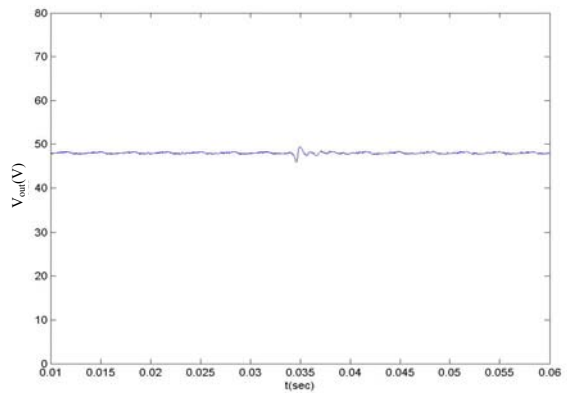

Fig. 19. Output voltage due to 15% reduction of the input voltages

References

- [1] Venturini M., "A new sine wave in, sine wave out, conversion technique eliminates reactive component," *Proc. POWERCON 7*, pp. E3-1-E3-15, 1980.
- [2] Nielsen P., Blaabjerg F. and Pedersen J. K., "New protection issues of a matrix converter: design considerations for adjustable speed drives," *IEEE Trans. on Industry Applications*, Vol. 35, No. 5, pp. 1150-1161, 1999.
- [3] Wheeler P. and Grant D., "Optimised Input Filter Design and Low-Loss Switching Techniques for A Practical Matrix Converter," *IEE Proc. Electr. Appl.*, Vol. 144, No. 1, pp. 53-60, 1997.
- [4] Wheeler P. W., Rodriguez J., Clare J. C., Empringham L. and Weinstein A., "Matrix Converters: A Technology Review," *IEEE Trans. On Industrial Electronics*, Vol. 49, No. 2, pp. 276-288, April 2002.
- [5] Wei L., Lipo T., and Chan H., "Matrix converter topologies with reduced number of switches," *IEEE Power Electronics Specialists Conference, PESC 2002*, pp. 57-63, 2002.
- [6] Jussila M., and Tuusa H., "Comparison of Simple Control Strategies of Space-Vector Modulated Indirect Matrix Converter under Distorted Supply Voltage," *IEEE Trans. on Power Electronics*, Vol. 22, No. 1, pp. 139-148, Jan. 2007.
- [7] Ratanapanachote S., Cha H. J. and Enjeti P. N., "A digitally controlled switch mode power supply based on matrix converter," *IEEE Trans. on Power Electronics*, Vol. 21, No.1, pp. 124-130, Jan. 2006.
- [8] Huber C., and Borojevic D., "Space vector modulated three-phase to three-phase matrix converter with input power factor correction," *IEEE Trans. on Industry Applications*, Vol. 31, No. 6, pp. 1234-1246, 1995.
- [9] Garcia-Gil R., Espi J. M., Dede J. M., Maset E.J., "An all-digital controlled AC-DC matrix converter with high-frequency isolation and power factor correction," *Proceedings of the IEEE International Symposium on Industrial Electronics*, France, pp. 1194-1199, 2004.
- [10] Ejea J. B., Sanchis-Kilders E., Carrasco J. A., de la Calle R., Espi J. M., "High-frequency bi-directional three-phase rectifier with power factor correction," *Power Electronics Specialists Conference, PESC. 2001 IEEE 32th Annual*, Vol. 3, pp. 1303-1308, 2001.
- [11] Holmes, D.G., Lipo, T.A., "Implementation of a controlled rectifier using AC-AC matrix converter theory," *IEEE Trans. on Power Electronics*, Vol. 7, No. 1; pp. 240-250, Jan. 1992.
- [12] Behrangi F., "Design and Simulation of a DC power supply based on dual bridge matrix converter," MS dissertation, Dept. of Electrical and Robotic Engineering, Shahrood Uni. Of Technology, Shahrood, Iran, 2008.
- [13] Erickson R. W. and Maksimovic D., "Fundamentals of Power Electronics," 2nd ed.; Norwell, Mass.: Kluwer Academic, 2000.
- [14] Wheeler P. W., Zanchetta P., Clare J. C., "A Utility Power Supply Based on a Four-Output Leg Matrix Converter," *IEEE Trans. on Industry Applications*, Vol. 44, No. 1, pp. 174-186, Jan. 2008.



Ali Dastfan was born in 1966 in Iran. He received the B.E. degree in 1989 from the University of Ferdosi, Mashhad, Iran, and the M.E. and Ph.D. degrees in Electrical Engineering from the University of Wollongong, Australia, in 1994 and 1998, respectively. He is currently with the Department of Electrical and Robotic

Engineering at Shahrood University of Technology in Iran. He is also member of IEEE and member of Iranian Association of Electrical and Electronic Engineering (IAEEE). His teaching and research interests include power electronics and power quality.



Farshid Behrangi graduated in power engineering from Khajeh Nasir Toosi University of Technology in 2004, and continued his education in power electronic field and received his master degree from Shahrood University of Technology in 2007. He worked on power supply and matrix converters in his graduate studies. His research interests include switch

mode power supply, matrix converter, high power converter and power quality.