

Enhancement of Robust Tracking Performance via Switching Supervisory Adaptive Control

O. Namaki-Shoushtari* and A. Khaki Sedigh*

Abstract: When the process is highly uncertain, even linear minimum phase systems must sacrifice desirable feedback control benefits to avoid an excessive ‘cost of feedback’, while preserving the robust stability. In this paper, the control structure of supervisory based switching Quantitative Feedback Theory (QFT) control is proposed to control highly uncertain plants. According to this strategy, the uncertainty region is suitably divided into smaller regions. It is assumed that a QFT controller-prefilter exists for robust stability and robust performance of the individual uncertain sets. The proposed control architecture is made up by these local controllers, which commute among themselves in accordance with the decision of a high level decision maker called the supervisor. The supervisor makes the decision by comparing the candidate local model behavior with the one of the plant and selects the controller corresponding to the best fitted model. A hysteresis switching logic is used to slow down switching for stability reasons. Besides, each controller is designed to be stable in the whole uncertainty domain, and as accurate in command tracking as desired in its uncertainty subset to preserve the robust stability from any failure in the switching.

Keywords: Switching Supervisory Adaptive Control, Robust Control, Quantitative Feedback Theory.

1 Introduction

According to Quantitative Feedback Theory, the feedback control is only justified to reduce the closed loop sensitivity to any kind of uncertainty, in the plant modeling or in the unmeasurable disturbances [1]. Thus, the amount of feedback is directly proportional to the amount of uncertainty and to the sensitivity reduction required. Besides, a unique controller cannot perform as well for a wide uncertainty plant set as for a smaller domain of uncertainty.

QFT is a powerful design methodology that provides a transparent trade-off between different often conflicting design specifications. It suggests a controller with minimum cost of feedback that satisfies the set of performance specifications in spite of the plant uncertainty [2], [3]. Let’s consider the loop transfer function $L(j\omega) = G(j\omega) P(j\omega)$. Using sufficiently large feedback (i.e. $|L| \gg |P|$) the effect of the plant uncertainty and of the disturbances could be diminished. On the

other hand, any practical $L(j\omega)$ must go to zero as $\omega \rightarrow \infty$, but robust stability implies that $|L|$ decreases relatively slowly with ω , [4]. Therefore, there is an intermediate frequency range where the excessive loop bandwidth due to feedback benefits amplifies sensor noise or disturbances at the plant input. This effect, which is called “cost of feedback”, results in the useful signal components of the input commands cannot pass into due to the saturation of elements of G and P .

For a highly uncertain process, in which parametric uncertainties are very large, finding a single controller that can deal with the entire range of parameter variations may be impossible or imply a poor performance. Therefore, the uncertainty reduction remains as the only solution. An infinite uncertainty division translates into classical adaptive control schemes where a particular controller is responsible for a unique plant identified in the uncertain domain. In order to overcome the limitations of adaptive control and to design a satisfactory control system in the presence of large modeling uncertainties, noise, and disturbances, a hierarchical control structure can be used. The control structure consists of a bank of candidate controllers supervised by a logic-based switching [5].

Iranian Journal of Electrical & Electronic Engineering, 2012.

Paper first received 2 May 2011 and in revised form 27 Nov. 2011.

* The Authors are with the Department of Systems and Control, Faculty of Electrical and Computer Engineering, K. N. Toosi University of Technology, P.O. Box 16315-1355, Tehran 1431714191, Iran.

E-mails: onomakis@ieeee.org and sedigh@kntu.ac.ir.

In each fixed, predetermined region of uncertainty, the local controller can achieve the desired performance. Switching is made between the local controllers to support all range of uncertainties. The overall control architecture consists of a bank of controllers (multi-controllers), and a supervisor. The supervisor is also composed of a bank of models (multi-estimators), a monitoring signal generator, and a switching logic. At each time instant, a high level decision maker, the so called supervisor, determines which controller should be placed in the feedback loop. In other words, when the estimation of the plant is changed, a new controller may be selected, which is similar to the idea of adaptive control. But unlike the traditional adaptive control strategies, this adaptation takes place in a discrete fashion. As a result, the overall closed loop system can be viewed as a hybrid system.

One of the main advantages of the supervisory control is its modularity [5]. Designing multi-estimators, multi-controllers, and switching logic can be done mutually independent. This feature enables the designer, to use “off-the-shelf” robust control laws. Based on this idea, in [6], a multi-model adaptive PID controller is developed and evaluated in a simulation study for a nonlinear pH neutralization process. A methodology that blends robust non-adaptive mixed μ -synthesis designs and stochastic hypothesis-testing concepts is introduced in [7].

In [8], linear limitations of linear robust controllers overcome by combining switching and QFT. Combining robust designs and switching, the designed controller optimizes the time response of the system by fast adaptation of the controller parameters during the transient response based on the error amplitude [8].

This paper shows the feedback tracking control limitations due to the uncertainty size in LTI minimum phase plants. These are discussed from the QFT bounds, computed with the formulas developed in [9]. The goal is to divide the uncertainty. Then, several QFT controllers are employed to attain robust stability and performance requirements despite uncertainties and disturbances. They also improve the feedback benefits and minimize the cost of feedback in their uncertainty subset. A supervisory architecture orchestrates

controller selection. This selection is based on the values of monitoring signals. To preserve robust stability despite of failure in the switching, each controller will be designed robustly stable for the full uncertainty range and as accurate in set-point tracking as desired in its uncertainty subset. This problem is also tackled in [10].

This paper is organized as follows: Section 2 examines fundamentals of QFT with the nature and severity of the QFT bounds. It also mentions the difficulties in loop shaping, revealing the limitations in the tracking feedback performance. In Section 3, switching supervisory control is reviewed. Our proposed design structure is described in Section 4. Simulation results and conclusions are made in Sections 5, and 6, respectively.

2 Quantitative Feedback Theory

The general QFT feedback structure is shown in Fig. 1.

The blocks to be designed by QFT in Fig. 1 are the controller and the pre-filter.

The QFT design, performed in the frequency domain, follows very closely classical designs using Bode plots. The model for the open-loop dynamics can either be fixed or include uncertainty. If the problem requires that the specifications be met with the uncertain dynamics, it is called a *robust performance* problem. That is, the performance specifications must be satisfied for all possible cases admitted by the specific uncertainty model [11].

Several performance specifications could be placed on any single loop closed loop relation. Some of the typical specifications considered in QFT are as follows:

- *gain and phase margins*

$$\left| F \frac{PG}{1+PG} \right| \leq W_{S1}$$

- *classical 2-DOF QFT tracking problem*

$$W_{S2a} \leq \left| F \frac{PG}{1+PG} \right| \leq W_{S2b}$$

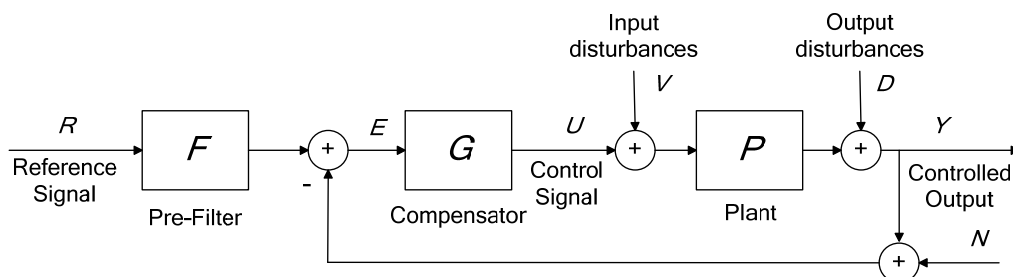

Fig. 1. The two-degrees of freedom structure of QFT [3].

- rejection of disturbance at plant output

$$\left| F \frac{1}{1+PG} \right| \leq W_{S_3}$$

- rejection of plant input disturbances

$$\left| F \frac{P}{1+PG} \right| \leq W_{S_4}$$

where W_{S_i} denotes the maximum tolerance model on the magnitude of certain transfer function from some inputs to some outputs in the frequency domain which is correspond to an specification placed on the magnitude of the transfer function. Then, to design the controller $G(j\omega)$, QFT translates these frequency domain specifications of an uncertain feedback system into bounds on the Nichols Chart that the nominal loop transmission $L_o(j\omega)$ must meet. Therefore, the bound arrangement is the key point in the controller synthesis process.

The necessary trade-offs among conflicting closed loop requirements are discussed in terms of QFT bounds in [9].

The loop-shaping $L_o = GP_o$ (P_o is the nominal plant) performed on the bound arrangement such that the QFT bounds are satisfied which result in the demanded performance specifications.

Robust stability bound makes $|L|$ decreasing comparatively slowly with ω . Thus, there is an intermediate range where $|L(j\omega)| \ll 1$ but $|L/P(j\omega)| > 1$ (to remove the effect of the plant ignorance). That means a dangerous amplification of the noise N at Y and U . Satisfyingly small output deviations can be achieved with available instrumentation. However, large $|L/P|$ peaks produce unavoidable large peaks in control input U [12], which is the main price paid for feedback, also referred in QFT as the ‘cost of feedback’ [1]. A large cost may saturate elements of G and P , in such a way that the useful signal components due to input commands cannot get through.

3 Switching Supervisory Control

In supervisory control of uncertain systems, the basic idea is to discretize the uncertainty set into a finite number of nominal values and then employ a family of controllers, one for each nominal value. Switching among the controllers is orchestrated by a supervisor in such a way that closed-loop stability is guaranteed. The benefits gained by this approach include (i) simplicity and modularity in design: controller design amounts to controller design for known linear time-invariant systems for which various computationally efficient controller design tools are available; (ii) ability to handle larger classes of systems than is possible with other approaches (see [5] for more discussion).

We quickly review here the supervisory control framework for adaptively controlling plants with large modeling uncertainty (see Fig. 2); for details, see e.g. ([13], Chapter 6), [14] or [5] and the references therein.

Consider an uncertain linear plant \mathcal{M}_p parameterized by a parameter p where p^* denotes the true but unknown parameter:

$$\mathcal{M}_{p^*} : \begin{cases} \dot{x} = A_{p^*} x + B_{p^*} u \\ y = C_{p^*} x, \end{cases} \quad (1)$$

where $x \in \mathbb{R}^{n_x}$ is the state, $u \in \mathbb{R}^{n_u}$ is the input, and $y \in \mathbb{R}^{n_y}$ is the output. The parameter $p^* \in \mathbb{R}^{n_p}$ belongs to a known finite set $\mathcal{P} = \{p_1, \dots, p_m\}$, where m is the cardinality of \mathcal{P} . It is assumed that (A_p, B_p) is stabilizable and (A_p, C_p) is detectable for every $p \in \mathcal{P}$.

The supervisor comprises a multi-estimator, monitoring signals, and a switching logic. The estimator-based supervisory control design for the system (1) is briefly outlined below:

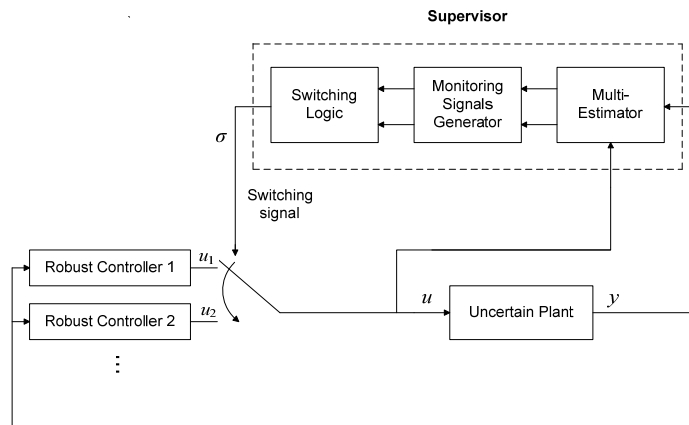

Fig. 2. The supervisory control framework [13].

• **Multi-estimator:** A multi-estimator is a collection of models, one for each fixed parameter $p \in \mathcal{P}$. The multi-estimator takes in the input u and produces a bank of outputs $y_p, p \in \mathcal{P}$. The multi-estimator should have the following matching property: there is $\hat{p} \in \mathcal{P}$ such that

$$\left| y_{\hat{p}}(t) - y(t) \right| \leq c_e e^{-\lambda_e(t-t_0)} \left| y_{\hat{p}}(t_0) - y(t_0) \right| \quad (2)$$

for all $t \geq t_0$, for all u , and for some $c_e \geq 0$ and $\lambda_e > 0$. One such multi-estimator for (1) is the following dynamics

$$\begin{aligned} \dot{x}_p &= A_p x_p + B_p u + L_p (y_p - y), \\ y_p &= C_p x_p, \end{aligned} \quad (3)$$

for all $p \in \mathcal{P}$, and the property (2) is satisfied with $\hat{p} = p^*$. The matrix L_p in (3) is such that the eigenvalues of $A_p + L_p C_p$ have negative real parts for each $p \in \mathcal{P}$. (since (3) with $p = p^*$ and (1) imply that $(d/dt)(x_{p^*} - x) = (A_{p^*} + L_{p^*} C_{p^*})(x_{p^*} - x)$ and $y = C_{p^*} x$).

• **Multi-controller:** A family of *candidate controllers* $\{G_p\}$ is designed such that the closed loop system meets the desired robust stability and performance specifications for every $p \in \mathcal{P}$. Then the *family of controllers* is

$$u_p, p \in \mathcal{P}. \quad (4)$$

• **Monitoring signals:** *Monitoring signals* $\mu_p, p \in \mathcal{P}$ are norms of the output estimation errors, $y_p - y$. Here, the monitoring signals are generated as

$$\mu_p := \varepsilon_0 + \int_0^t e^{-\lambda(t-s)} \gamma \left| y_p(s) - y(s) \right|^2 ds \quad (5)$$

for some $\gamma, \varepsilon_0, \lambda > 0$. The numbers γ, ε_0 , and λ are design parameters and need to satisfy

$$0 < \lambda < \lambda_0 \quad (6)$$

for some constant λ_0 related to the eigenvalues of the closed-loop system (for details on λ_0 , see [13]).

• **Switching logic:** A switching logic produces a switching signal that nominates the active controller at each time instant. In this paper, we use the *scale independent hysteresis switching logic* [15]:

$$\sigma(t) := \begin{cases} \arg \min_{q \in \mathcal{P}} \mu_q(t) & \text{if } \exists q \in \mathcal{P} \text{ such that} \\ & (1+h)\mu_q(t) \leq \mu_{\sigma(t^-)}(t) \\ \sigma(t^-) & \text{else,} \end{cases} \quad (7)$$

where $h > 0$ is called a *hysteresis constant* and is a design parameter that prevents excessive switching. Both in theory and in practice, it is important that excessive switching be avoided. The use of a hysteresis

term conveniently satisfies this requirement. The control signal applied to the plant is $u(t) = u_\sigma(t)$.

4 Switching Supervisory QFT Control

Combining switching and QFT was first introduced in [8] to prioritize some specifications over others according to the state of the system at each time. Switching is used to select the appropriate controller, which is determined based on the error amplitude. Two controllers are used: the fast, more stable and imprecise controller is used when the output is too far from the reference, or equivalently when the error amplitude is large. When the error is small, a controller, which reduces the bandwidth, is used to avoid the effects of noise, and meanwhile to increase the low frequency gain in order to minimize the jitter and the tracking error.

In that method, both of the controllers are supposed to have the same poles, so that graphical stability criteria can be utilized. This constraint limits the type of controllers and therefore the performance of the system. So, a more general approach is introduced to overcome this limitation.

4.1 Problem Formulation

In the case of highly uncertain plants, two distinct cases can occur:

- A single QFT controller exists for the entire uncertainty range. However, the closed loop performance may not be improved further as desired.
- A single QFT controller does not exist to ensure closed loop robust stability and performance.

In both cases, the QFT strategy needs improvements to fulfill the practical design requirements and to meet the challenges of the control of difficult highly uncertain plants.

4.2 Class of Admissible Plants

The goal is to design a control system, which can track a predetermined set point in case of plant uncertainty and disturbances. The plant is assumed to be modeled by a stabilizable and detectable SISO linear system with control input u and measured output y , perturbed by a bounded disturbance input d . It is also assumed that the plant transfer function belongs to a known class of admissible transfer functions of the form:

$$\mathcal{M} := \bigcup_{p \in \mathcal{P}} \mathcal{M}_p$$

where p is a parameter taking values in some index set. \mathcal{M}_p is also a family of transfer functions “centered” around some known *nominal* process model transfer function v_p [16]. Allowable unmodeled dynamics around the nominal process model transfer functions v_p could be specified as:

$$\mathcal{M}_p := \{v_p(1 + \delta_m) + \delta_a : \|\delta_m\|_{\infty, \lambda} \leq \varepsilon, \|\delta_a\|_{\infty, \lambda} \leq \varepsilon\},$$

where $\varepsilon > 0$ and $\lambda \geq 0$ are two arbitrary numbers. Here, $\|\cdot\|_{\infty, \lambda}$ denotes $e^{-\lambda t}$ -weighted \mathcal{H}_∞ norm of a transfer function: $\|v\|_{\infty, \lambda} := \sup_{\text{Re}[s] \geq 0} |v(s-\lambda)|$ [16].

Throughout the paper, we will take \mathcal{P} to be a compact subset of a finite-dimensional normed linear vector space.

By this definition, the entire region of plant uncertainty is partitioned into a set of smaller regions. Each smaller region is presented by a parameter value p , and \mathcal{M}_p is a model of the plant in that small region.

Considering all permissible uncertainties and disturbances in each smaller region, a controller is designed to perform robust stability and robust set point tracking specifications, via QFT.

4.3 Multi-Estimator and Multi-Controller

A state-shared multi-estimator of the form

$$\dot{x}_E = A_E x_E + L_E y + B_E u, \quad y_p = C_p x_E, \quad e_p = y_p - y, \quad (8)$$

where $p \in \mathcal{P}$, and A_E an asymptotically stable matrix, is utilized here. This type of structure is quite common in adaptive control ([17]). Note that even if \mathcal{P} is an infinite set, the above dynamical system is finite-dimensional. In this case the multi-estimator formally has an infinite number of outputs; however they can all be computed from x_E . Here we use state-sharing not only to generate the estimation errors e_p , but also in the monitoring signal generator for μ_p .

For practical reasons the bank of local controllers can be efficiently implemented (multirealized) by means of a state-shared parameter dependent feedback system. The provided method can implement bumpless transfer, which is an effective way to improve poor transient response of switched systems [17], [18].

5 Simulation Results

In this section, a practical example is used to illustrate the proposed design method. Consider a DC field-controlled motor, whose nominal parameters are given in Table 1. Assuming that the angular velocity Ω is the plant output to be controlled, and the field voltage V_f is the manipulated variable, the transfer function corresponds to the DC motor is ([19]):

$$\mathcal{M}(s) = \frac{\Omega}{V_f} = \frac{K_m/R_f}{Js + b} = \frac{K}{Js + b}, \quad (9)$$

where the electrical time constant L_f/R_f is ignored compared to the mechanical time constant J/b (see Table 1). Due to temperature variations and some other effects, the motor parameters may differ from the nominal values. Therefore, a 20% variation in b and a 5% deviation in K from their nominal values are considered in this example. Moreover, the larger difference for this real application relates to the rotor inertia J . Its value is expected to change between $J = 0.01$ as the nominal value which is correspond to no load and $J = 0.1$ as the full load condition, respectively.

The closed-loop desired specifications for speed control are:

(1): Robust stability in terms of a margin specification (L is the loop gain)

$$\left| \frac{L}{1+L} \right| \leq 1.3, \quad \omega > 0$$

This would indicate a gain margin and phase margin of 4.9dB and 45deg respectively.

(2): Robust tracking specification enforced to $\omega_n = 10$ rad/sec.

$$\frac{8400}{(s+3)(s+4)(s+10)(s+70)} \leq T_r \leq \frac{0.6584(s+30)}{s^2+4s+19.75}$$

where $T_r = F \frac{PG}{1+PG}$ is the transfer function from reference input to the output.

(3): A low enough high frequency loop gain to reduce the 'cost of feedback', e.g. $|L(j\omega_{hf})| < -20$ dB, $\omega_{hf} \geq 100$ rad/sec.

The main steps involved in the design of the QFT controllers, such as template generation, loop shaping, pre-filter design, manipulation of tolerance bounds within the available freedom, template size considerations and selection of nominal transfer functions all require much experience and expertise. In [20] the various steps of quantitative designs are reformulated and presented in terms of appropriate cost functions and respective algebraic constraints. The resulting nonlinear constrained optimization problem can easily be solved using the Genetic Algorithm. Here, the QFT designs are adopted from [19]. The QFT controller and pre-filter, which is designed for the whole uncertainty range, are the followings:

Table 1 Nominal Parameter Values for a DC Field-Controlled Motor

Symbol	Parameters	Nominal values
J	No Load Rotor Inertia (kg m ²)	0.01
b	Friction (N m s)	0.1
K_m	Motor Constant (N m/A)	0.05
R_f	Field Resistance (Ω)	1
L_f	Field Inductance (H)	$\ll 0.1$

$$G(s) = 37.71 \frac{\frac{s}{0.1} + 1}{s(\frac{s}{175.5} + 1)}, F(s) = \frac{28}{s^2 + 11s + 28}$$

Note that the controller should have a pole at the origin to avoid steady state tracking error.

In this case, a single QFT design could not cover the whole uncertainty range. It is impossible to find a QFT controller-prefilter that meets explicit bounds on stability and tracking specifications in (1) and (2), and that cuts off simultaneously the implicit cost of feedback in (3). This performance limitation was argued in Section 2.

Fig. 3 simulates the time domain performance of the aforementioned QFT design for the plant with $J=J_{max}$, $b=b_{max}$, $K=K_{min}$. This is the plant with more difficulties to track the input signal since it represents the biggest load and friction for the smallest motor constant; and it needs the maximum control effort value; this plant is also the nominal plant taken in the QFT design. Nevertheless, the worst saturation effects (higher cost of feedback) occur in the plant with the biggest $|L|$, that is, the plant which corresponds to $J=J_{min}$, $b=b_{min}$ and $K=K_{max}$. Fig. 3(a) shows an acceptable tracking performance for $J=J_{max}$, $b=b_{max}$ and $K=K_{min}$. However, the sensor noise is highly amplified in the control input as Fig. 3(b). The situation deteriorates for $J=J_{min}$, $b=b_{min}$ and $K=K_{max}$ (Fig. 4(b)). In practice, this huge cost of feedback saturates the armature core, spoiling the expected performance in Fig. 3(a) as shown by Fig. 4(a).

The cost of feedback can be reduced by relaxing the tracking specifications. In other words, the cost of feedback reduction is not for free. It also implies spoiling the control tracking performance. The solution planned in this paper is the division of the uncertainty. Thus, switching QFT design is implemented to overcome this difficulty.

An *identifier-based* estimator Σ_E for this system may be constructed of the following form as in [17].

$$\dot{x}_E = \begin{bmatrix} A_E & 0 \\ 0 & A_E \end{bmatrix} x_E + \begin{bmatrix} b_E \\ 0 \end{bmatrix} y + \begin{bmatrix} 0 \\ b_E \end{bmatrix} u \quad (10)$$

$$y_p = c_p x_E$$

where (A_E, b_E) a stable parameter-independent, controllable pair, and

$$\left\{ \begin{bmatrix} A_E & 0 \\ 0 & A_E \end{bmatrix} + \begin{bmatrix} b_E \\ 0 \end{bmatrix} c_p, \begin{bmatrix} 0 \\ b_E \end{bmatrix}, c_p \right\} \quad (11)$$

is a stabilizable realization of $\mathcal{M}(s)$. A state-shared implementation of this multi-estimator is then used in the supervisor.

It is possible to construct a multi-estimator Σ_E for this example by picking any one-dimensional

controllable pair (A_E, b_E) with A_E stable, and then defining c_p so that it represents the plant uncertainty. For simplicity, (A_E, b_E) is chosen to be in control canonical form and that A_E 's characteristic polynomial ω_E is $s + \omega$, where ω is a design parameter. Under these conditions c_p appears to be the following vector:

$$c_p := \begin{bmatrix} \omega - \frac{b}{J} & \frac{K}{J} \end{bmatrix}$$

The performance signals μ_p , $p \in \mathcal{P}$ are then constructed using the idea of state-sharing in a similar way as in [13], [17].

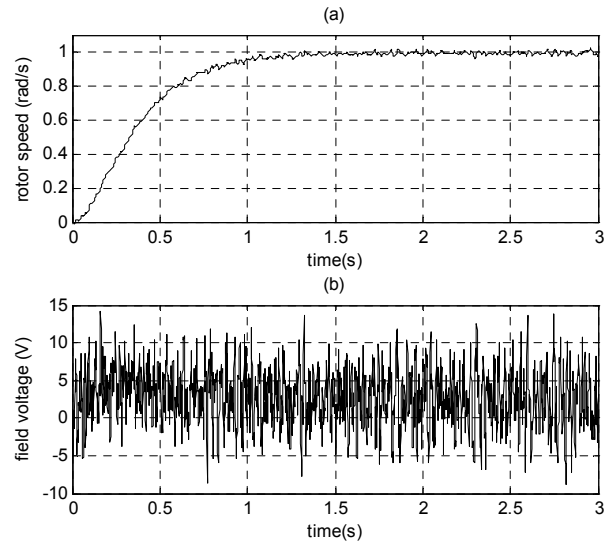

Fig. 3. Simulation results for the plant $J=J_{max}$, $b=b_{max}$ and $K=K_{min}$ in the full uncertainty set (Single QFT design) (a) output tracking performance and (b) control effort.

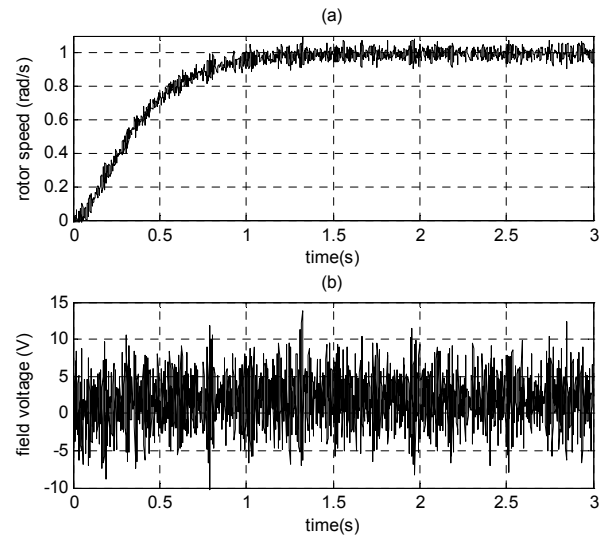

Fig. 4. Simulation results for the plant $J=J_{min}$, $b=b_{min}$ and $K=K_{max}$ in the full uncertainty set (Single QFT design) (a) output tracking performance and (b) control effort.

The J uncertainty contributes strongly in both magnitude and phase uncertainty in the templates at mid frequencies. In other words, J is the most significant uncertain parameter in the parameters space. In the following, we divide the uncertain system into smaller subsystems based on this uncertain parameter. So, to design the multiple-model based switching architecture the rotor inertia uncertainty is divided into two smaller parts, $J_1 = [0.01 \ 0.05]$ and $J_2 = [0.05 \ 0.1]$.

Now, for each uncertainty region, a QFT design is employed to achieve robust stability and performance despite the corresponding uncertainties. The resulting controllers are as follows:

$$G_1(s) = 16.2 \frac{\frac{s}{2.1} + 1}{s(\frac{s}{26.7} + 1)}, \quad G_2(s) = 27.7 \frac{\frac{s}{3.7} + 1}{s(\frac{s}{18.61} + 1)}$$

The prefilters for these new designs are the same as the previous one used in the first QFT design. Eventually, a supervisory architecture determines the active controller, which should be placed in the feedback loop. This selection is based on the values of monitoring signal. A schematic diagram of the overall multiple-model based switching algorithm is depicted in Fig. 5. Further details on the implementation of Adaptive Control via Switching and Supervisory can be found in [13] (chapter 6) and [14] (chapter 5).

To proceed with simulation, assume that the parameters of the real (unknown) plant are $J=J_{max}$, $b=b_{max}$, $K=K_{min}$. In addition, the hysteresis constant h in the switching law (7) is set to $h = 0.1$. Suppose that the second candidate controller (G_1) is connected into the loop initially, that is, $\sigma(0) = 1$. Fig. 6 depicts the closed-loop input-output trajectories, which shows satisfactory closed-loop performance. The switching signal identifies the “right” controllers via one switch. Furthermore, we set the first controller initially, i.e.,

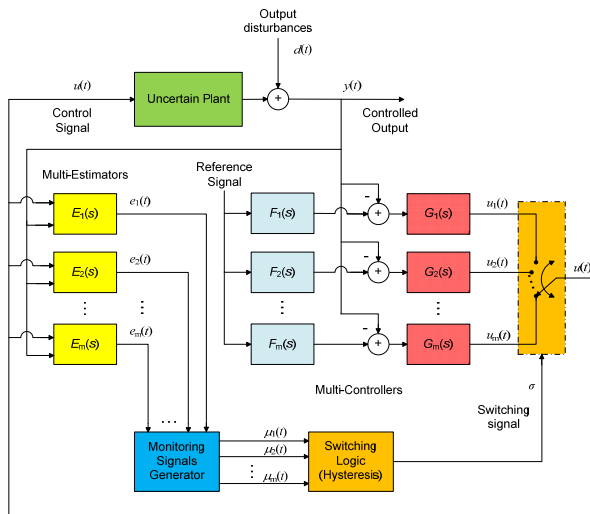

Fig. 5. The Supervisory Based Switching QFT control architecture [10].

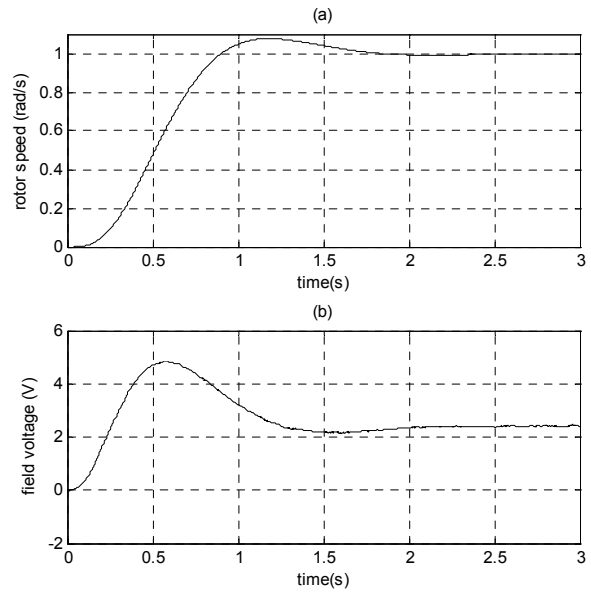

Fig. 6. Supervisory Switching QFT control simulation for for the plant $J=J_{max}$, $b=b_{max}$ and $K=K_{min}$ (a) output tracking performance and (b) control effort.

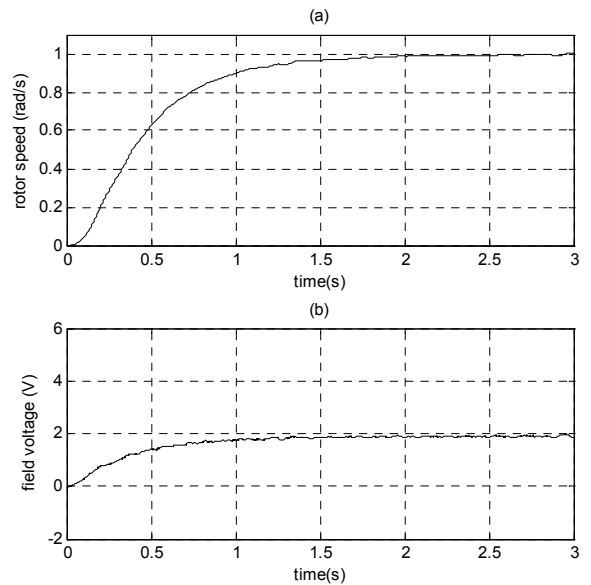

Fig. 7. Supervisory Switching QFT control simulation for the plant $J=J_{min}$, $b=b_{min}$ and $K=K_{max}$ (a) output tracking performance and (b) control effort.

$\sigma(0) = 2$, and carry out the simulation again for plant which corresponds to $J=J_{min}$, $b=b_{min}$ and $K=K_{max}$. Simulation results are given in Fig. 7. The “right” controller is identified by the supervisor and the closed loop performance is satisfactory.

Figs. 6 and 7 verify the time performance of the switching QFT design. Compare them to Fig. 3(a) and Fig. 4(a), and note that G_1 and G_2 improve the tracking performance yielded by G (single QFT design for the full uncertainty). Besides, G_1 and G_2 reduce considerably the cost of feedback.

6 Conclusions

This paper dealt with the feedback performance limitations for highly uncertain plants. A large uncertainty may imply a poor tracking performance to avoid an excessive cost of feedback, which would saturate the actuators, and guaranteeing an acceptable robust stability. The solution proposed was to suitably divide the uncertainty region. Different QFT controllers were employed to maximize the feedback benefits and minimize the cost of feedback in their uncertainty subset. In addition, they were robustly stable in the full uncertainty domain. The application of QFT in switching multiple model based adaptive control was presented. The control structure proposed consists of a bank of candidate state-shared compensators and a supervisor. Each of the candidate controllers is designed in order to achieve the demanded performance in a region of the plant uncertainty. The supervisor consists of a state-shared multi-estimator, a performance signal generator and a hysteresis switching logic scheme. The supervisor chooses the active controller corresponding to the local model which best fits the plant data. Simulation results on a practical example show the performance of this algorithm for controlling highly uncertain plants.

References

- [1] Horowitz I.M., *Synthesis of Feedback Systems*. Academic Press: New York, 1963.
- [2] Horowitz I., "Survey of quantitative feedback theory (QFT)", *International Journal of Control*; Vol. 53, No. 2, pp. 255-291, 1991. Also in *International Journal of Robust and Nonlinear Control*; Vol. 11, pp. 887-921, 2001.
- [3] Houppis C. H., Rasmussen S. J. and Garcia-Sanz M., *Quantitative Feedback Theory: Fundamentals and Applications* (2nd edition). A CRC Press Book, Taylor & Francis: Florida, 2006.
- [4] Bode H.W., *Network Analysis and Feedback Amplifier Design*. Van Nostrand: New York, USA, 1945.
- [5] Hespanha J. P., Liberzon D. and Morse A. S., "Overcoming the limitations of adaptive control by means of logic-based switching," *Systems and Control Lett.*, Vol. 49, No. 1, pp. 49-65, 2003.
- [6] Böling J. M., Seborg D. E. and Hespanha J. P., "Multi-model adaptive control of a simulated pH neutralization process," *Control Engineering Practice*, Vol. 15, pp. 663-672, 2007.
- [7] Fekri S., Athans M. and Pascoal A., "Issues, progress and new results in robust adaptive control," *Int. J. Adapt. Control Signal Process.*; Vol. 20, pp. 519-579, 2006.
- [8] Garcia-Sanz M. and Elso J., "Beyond the linear limitations by combining Switching & QFT. Application to Wind Turbines Pitch Control Systems". Special Issue: "Wind Turbines: New Challenges and Advanced Control Solutions". *International Journal of Robust and Nonlinear Control*, Vol. 19, No. 1, pp. 40-58, 2009.
- [9] Gil-Martinez M. and Garcia-Sanz M., "Simultaneous meeting of robust control specifications in QFT," *International Journal of Robust and Nonlinear Control*, Vol. 13, pp. 643-656, 2003.
- [10] Namaki-Shoushtari O. and Khaki Sedigh A. "Design of Supervisory Based Switching QFT Controllers for Improved Closed Loop Performance" in Proceedings of the 18th Iranian Conference on Electrical Engineering, ICEE 2010, Isfahan, Iran, May 2010, pp. 599-604.
- [11] Borghesani C., Chait Y., and Yaniv O., *Matlab Quantitative Feedback Theory Toolbox v2.0*, Terasoft, Inc., 2003.
- [12] Horowitz I. M. and Sidi M., "Synthesis of feedback systems with large plant ignorance for prescribed time-domain tolerances," *Int. J. Control*, Vol. 16, No.2, pp. 287-309, 1972.
- [13] Liberzon D., *Switching in Systems and Control*. Birkhäuser, Boston, 2003.
- [14] Sun Z., and Ge S. S., *Stability Theory of Switched Dynamical Systems*, Springer-Verlag London, 2011.
- [15] Hespanha J. P., Liberzon D., and Morse A. S., "Bounds on the number of switchings with scale independent hysteresis: Applications to supervisory control", In Proc. of the 39th Conf. on Decision and Contr., Vol. 4, pp. 3622-3627, Dec. 2000.
- [16] Hespanha J. P., Tutorial on supervisory control. Lecture notes for the workshop control using logic and switching for the 40th IEEE CDC, Orlando, FL, 2001.
- [17] Morse A. S., "Supervisory control of families of linear set-point controllers-part 1: exact matching," *IEEE Trans. Automat. Control*, Vol. 41, No. 10, pp. 1413-1431, 1996.
- [18] Morse A. S., Control using logic-based switching. In A. Isidori, editor, *Trends in Control: an European Perspective*, pages 69-113. Springer-Verlag, London, 1995.
- [19] Gil-Martinez M. and Garcia-Sanz M., "Robust tracking performance enhancement through uncertainty division", In Proc. of the 7th European Control Conference, ECC'03, Cambridge, United Kingdom, September 2003.
- [20] Khaki-Sedigh A. and Lucas C., "Optimal design of robust quantitative feedback controllers using random optimization techniques", *International Journal of Systems Science*; Vol. 31, No. 8, pp. 1043-1052, 2000.



Omid Namaki-Shoushtari received his B.Sc. and M.Sc. degrees in Electrical Engineering (control systems) from University of Tehran, Tehran, Iran, in 2002 and 2005, respectively. He received his Ph.D. in Electrical Engineering (control systems) in 2011 from K.N. Toosi University of Technology, Tehran, Iran.

His research interests include switching supervisory control, advanced process control, robust adaptive control and nonlinear control systems.



Ali Khaki Sedigh is currently a professor of control systems with the Faculty of Electrical and Computer Engineering, K.N. Toosi University of Technology, Tehran, Iran. He obtained an honors degree in mathematics from University of Newcastle upon Tyne in 1983, masters in Control Systems from UMIST in 1985, and Ph.D. in Control

Systems from University of Salford in 1988, all in UK. He is the author and co-author of about seventy journal papers and has published ten books in the area of control systems. His main research interests are adaptive and robust multivariable control systems, chaos control, hybrid systems, and the history of control.