

# Sensitivity Analysis and Stray Capacitance of Helical Flux Compression Generator with Multi Layer Filamentary Conductor in Rectangular Cross-Section

M. E. Mosleh\*, M. R. Besmi\*

**Abstract:** The calculation of stray capacitance (SC) between adjacent coils as series capacitance and between coil and liner as shunt capacitance are very important to consider in the design of a magnetic flux compression generator (MFCG). This paper presents an approach to calculate the equivalent stray capacitance (SC) of n-turn of the helical flux compression generator (HFCG) coil with multi layer conductor wire filaments (MLCWF) in the form of rectangular cross-section. This approach is based on vespiary regular hexagonal (VRH) model. In this method, wire filaments of the generator coil are separated into many very small similar elementary cells. By the expanded explosion in the liner and move explosion to the end of the liner, the coil turns number will be reduced. So, the equivalent SC of the HFCG will increase. The results show that by progress of explosion and decrease of the turns' number in the generator coil; total capacitance of the generator increases until the explosion reaches to the second turn. When only one turn remains in the circuit, a decrease occurs in the total capacitance of the generator.

**Keywords:** Magnetic flux compression generator, multi-layer, stray capacitance, vespiary model.

## 1 Introduction

The magnetic flux compression generator (MFCG) offers the largest pulsed power output per unit size or weight when compared with other conventional systems [1]-[2]. These generators are capable of producing voltages of hundreds kilovolt and currents of tens to hundreds mega ammeter.

The different types of flux compression generators have been developed and tested during the past years. The most successful types of them, is the helical flux compression generator (HFCG), which is capable of producing a very high energy output into large impedance loads, which is needed for a practical pulsed power source. Ultra-high magnetic fields in compression generator and solid-state physics are presented in [3]-[6].

In the design of HFCG (see Fig. 1.), in order to well and correct performance, we need to obtain a geometrical model with sufficient accuracy and

appropriate characteristics of geometrical components.

The literatures review show that, the conventional models of HFCG didn't consider the effects of stray capacitances. Recently, the stray capacitance of HFCG is considered in [7] for a coil with the N-turns and solid rectangular cross section, and in [8] for a coil with one turn and multi-filaments.

One of the important structures of practical MFCG is in the form of helix, which mentioned before as HFCG. This practical structure has the multi-layer in each turn and many turns to produce the high magnetic field. So, this paper is related to studying the HFCG and development of single turn study, which is proposed in [8] for multi-layers in each turn and multi-turns.

However, problems related to the stray ac winding resistance, core losses [9]-[10], the stray capacitance of coils of electronic and electric circuits in very small dimensions [11]-[14], stray capacitance and field of power transformers [15]-[17], and the effect of different kinds of inter-turn winding faults on magnetic flux linkage [18] are discussed and analyzed in the mentioned literatures. However, we have not seen any trace of these studies in the design of MCG until 2011.

Iranian Journal of Electrical & Electronic Engineering, 2012.

Paper first received 22 May 2011 and in revised form 23 Oct. 2011.

\* The Authors are with the Department of Electrical Eng., Shahed University, Tehran, Iran.

E-mails: omidezati2000@yahoo.com and besmi@shahed.ac.ir.

Therefore, the aim of this paper is to develop the latest studies on stray capacitance, which is presented in [8].

In HFCG, the effects of electric field will be too much because of the voltage increase in each turn during explosion progress and decrease the number of coil turns. So the lines of electric field produced between the turns of the coil and also between the turn and cylindrical liner, which is placed at the coil center. Therefore, the electric fields make turn-turn ( $C_{tt}$ ) and turn-liner ( $C_{tl}$ ) capacitances. High Frequency in the coil makes skin effect and proximity effects, which finally causes the increase of resistance of the coil turns. Moreover, because of series and shunt capacitances in the system, resultant impedance of the generator will be increased.

To calculate the total capacitance of the HFCG, we need to calculate SC between:

- conductor wire filaments (CWF) in one turn (wire filament-wire filament) ( $C_{ss}$ )
- wire filaments of one turn of the coil and liner (wire filament-liner) ( $C_{sl}$ )
- coil turns (turn-turn) ( $C_{tt}$ )
- turn – liner ( $C_{tl}$ )

Total stray capacitance of the coil can be modeled by a lumped capacitance ( $C$ ) connected between the terminals of the coil, as shown in Fig. 2 [5]. Stray capacitance of the coil is a disturbing factor and has a significant effect on the generator function. The purpose of this paper is to calculate the SC of n-turns of the generator coil with rectangular cross-section, including k-conductor wire filaments (k-CWF), Figs. 3 and 4.

## 2 Algorithm and Method of Capacitance Calculation

Algorithm used in this paper is as follows:

- Considering an overall model for equivalent circuit of n-turns of the generator coil.
- Calculation of a filament-filament ( $C_{ss}$ ) and filament-liner ( $C_{sl}$ ) capacitance.
- Calculation of a capacitance between two filament turns ( $C_{stst}$ ) from two adjacent turns.
- Calculation of a turn-turn capacitance ( $C_{tt}$ ) between adjacent turns, using results of the step(c).
- Calculation of a turn-liner capacitance ( $C_{tl}$ ) between a turn and liner using results of the step (b).
- Calculation of the total parasitic capacitance ( $C(n)$ ) for n-turns of the coil with a conductor, which is composed of k-CWF include a multi-layer (using step (d)&(e)).
- Simulation of the total parasitic capacitance ( $C(n)$ ) for n turns of the coil (NTC); with a multi-layer conductor and k-CWF in each turn, using results of step (f).

Total stray capacitance of the generator coil can be modeled by a lumped capacitance ( $C$ ) connected between the terminals of the coil, as shown in Fig. 2, [5].

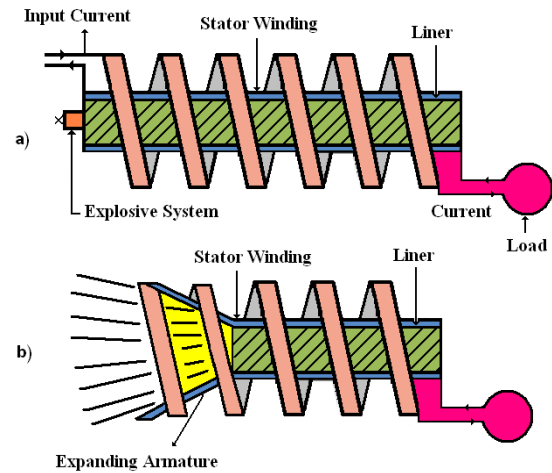

Fig. 1 Helical magnetic flux compression generator (HFCG): (a) before explosion, (b) during explosion.

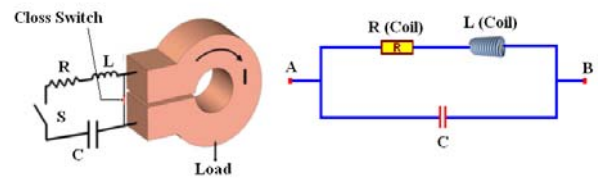

Fig. 2 Equivalent circuit of the coil of HFCG.

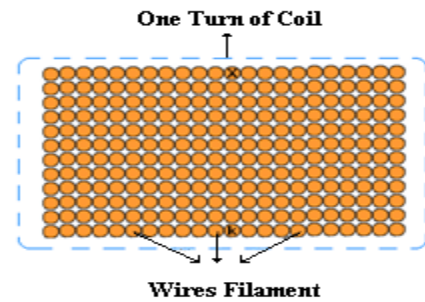

Fig. 3 Rectangular cross-section of one turn of the HFCG coil includes multi-layer k-CWFs in one turn.

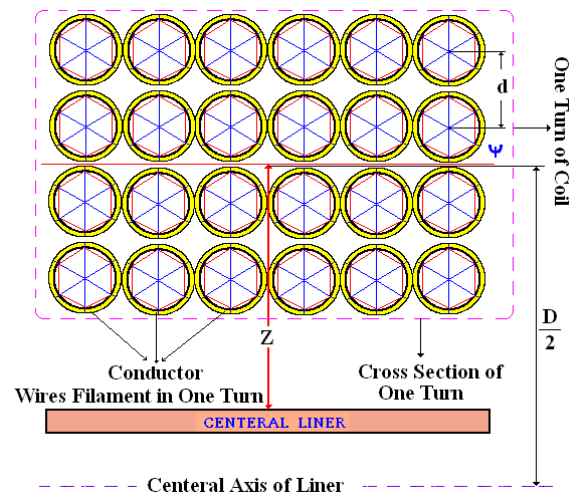

Fig. 4 Rectangular cross-section of one turn of the HFCG coil with m-layer conductor and k-CWF in non-real scale and view of VHR model in one turn of coil (OTC).

In one turn of the coil (OTC), there are following capacitance, which are shown in Fig. 5:

- 1- Filament-filament capacitance ( $C_{ss}$ ) between non-adjacent wire filaments in one turn of the coil.
- 2- Filament-filament capacitance ( $C_{ss}$ ) between adjacent wire filaments in one turn of the coil.
- 3- Filament-liner capacitance of ( $C_{sl}$ ).

In N turns of the coil (NTC), there are following capacitance, which are shown in Fig. 6:

- Turn-turn capacitance ( $C_{tt}$ ) between non-adjacent turns.
- Turn-turn capacitance ( $C_{tt}$ ) between adjacent turns of coil.
- Turn- liner capacitance ( $C_{tl}$ ).

To calculate the above capacitances, there are some assumptions, which are presented in [7] and [8].

Fig. 4 shows the cross-section of one turn of a coil (OTC) with a multi-layer of CWF, which has been

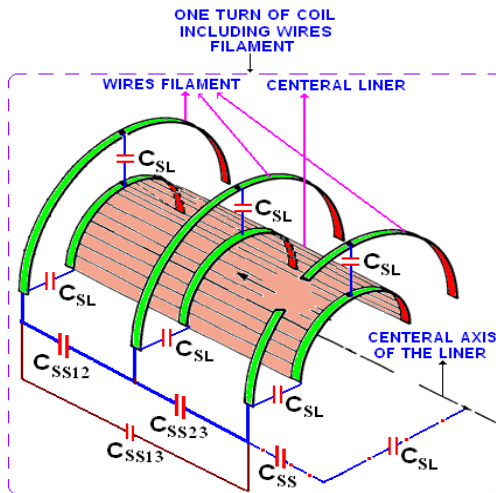

**Fig. 5** View of the total stray capacitance of one turn of coil (OTC). includes multi-layer k-CWF of the generator in non-real scale.

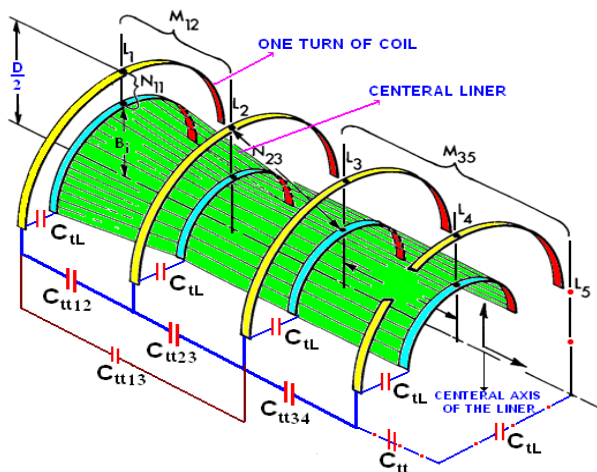

**Fig. 6** View of stray capacitance of n-turns of coil of the HFCG.

wounded uniformly. In order to calculate the capacitance between two CWF of OTC, we consider a regular hexagon with perfectly equal angles of  $2\pi/3$  radian. Each side is equal to  $y$ . Now, consider an equilateral lozenge-shape basic cell (ELBC) composed of two trapezoid-shape regions (regions1 and 2 of Fig. 8). Extension of the sides of this equilateral lozenge will pass from two adjacent apex of the hexagon and will be tangent to external surfaces of adjacent CWF. This method of capacitance calculation is called vespiary regular hexagonal (VHR) [8].

Fig. 7 shows lozenge basic cell “abcd” related to filament-filament capacitance ( $C_{ss}$ ). From Figs. 4 and 7, we can find geometric symmetry of CWF of OTC. By considering this geometric symmetry of CWF, fraction of electric field lines which exit from a CWF, is completely surrounded by other CWF around this CWF. By considering the geometric symmetry of the coil, electric field lines should be divided equally among adjacent CWF. If we consider two closer adjacent CWF in one turn, then elementary capacitance,  $dC$  between two elementary surfaces of these two CWF with area of  $dS$ , which are opposite to each other is:

$$dC = \epsilon_0 \cdot \epsilon_r \frac{ds}{g(\beta)}, \quad (1)$$

where,  $\epsilon_r$  is the relative permittivity and  $\epsilon_0$  is the vacuum permittivity and  $g(\beta)$  is the length of electric field lines between two elementary conductor surfaces, and  $\beta$  is an angle, which is shown in Fig. 8.

### 3 Filament-Filament Capacitance Between Two CWF in OTC [8]

#### 3.1 Structure of ELBC of VHR Model.

Fig. 7 shows an equilateral lozenge basic cell 'abcd' which forms filament-filament capacitance ( $C_{ss}$ ). It was clearly seen that the geometric structure of the basic cell is the same for two adjacent CWF of the same layer and two adjacent CWF of different layers. Thus, internal region of the cross-section of one turn of the coil could be divided into similar basic cells. Only adjacent cells to the central cylindrical liner will be different from filament-filament cell.

By an approximation and simple preliminary assumption, we can suppose all the basic cells to be similar and identical. These basic cells include a region of the periphery of the CWF, which correspond to angle of  $\pi/3$  radian. This expression can be accepted for CWF, which is completely surrounded by other CWF, because of geometric symmetry as shown in Figs. 4, 7 and 8.

By approximation, we can neglect the edge capacitance and fringing effects. Therefore, we can use the same angle of  $\pi/3$  radian for CWF, which aren't perfectly surrounded. For equilateral lozenge-shape basic cell (ELBC) shown in Fig. 7, three different regions are crossed by electric field as follows:

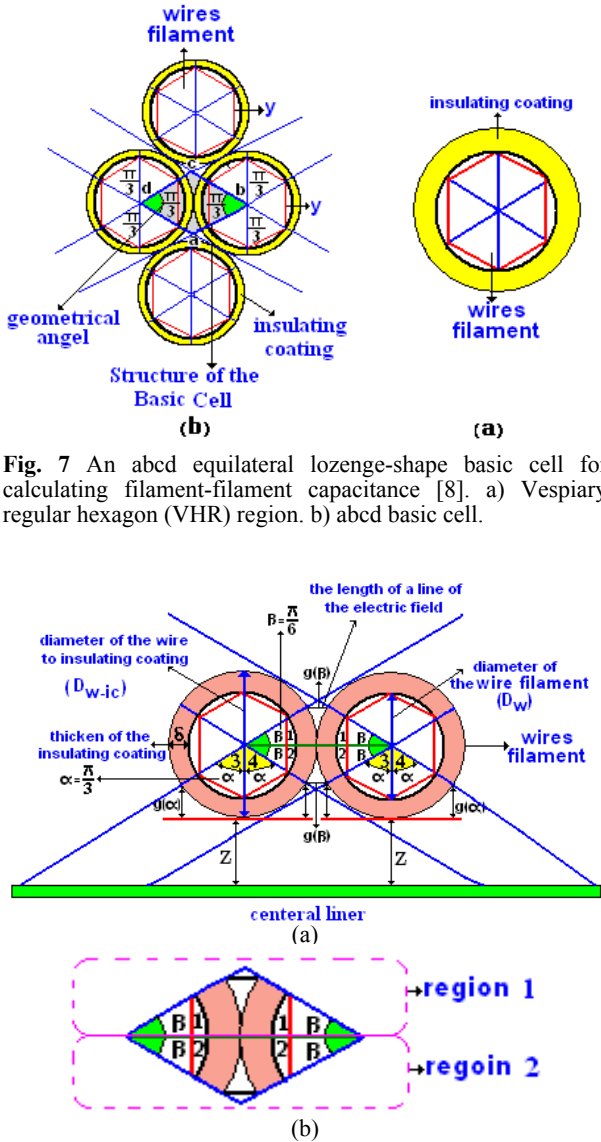

**Fig. 7** An abcd equilateral lozenge-shape basic cell for calculating filament-filament capacitance [8]. a) Vespiary regular hexagon (VHR) region. b) abcd basic cell.

approximation, we can consider the shortest possible path which is parallel to the line connecting two centers of two adjacent circular of CWF, as the path of the electric field lines under consideration. This approximation applies for small amounts of  $\beta$  angle, which has a main role in filament-filament capacitance ( $C_{ss}$ ). For the big amounts of  $\beta$ , error of this approximation will be increased, so that the big value of  $\beta$  lead to increase the capacitance value in comparison with the actual value. Anyway, the filament-filament capacitance of surfaces will decrease when  $\beta$  is increased. Also by increasing of  $\beta$ , the value of error produced in capacitance will be negligible.

### 3.2 Capacitance of Insulating Coating ( $C_{ic}$ ) Between Two Adjacent CWF in OTC of the Generator

In this section, a method is presented to calculate capacitance of insulating coating in one turn of the HFCG coil. Fig. 9 shows a cylindrical elementary surface placed between the surface of CWF and the surface of insulating coating.

Elementary capacitance related to this cylindrical insulating will be:

$$dC_{ic} = \epsilon \frac{ds}{g(\beta)} = \epsilon_0 \cdot \epsilon_r \cdot \frac{r_{ic} \cdot d\beta \cdot dh}{dr_{ic}} \quad (2)$$

Integrating this equation over the radius ( $r$ ); from the radius of CWF without insulating coating ( $r_w$ ) to outer radius of CWF with insulating coating ( $r_{w-ic}$ ), and over  $h$  (turn length of CWF) from zero to turn length of CWF ( $l_{ts}$ ). Therefore, the capacitance of insulating coating limited to elementary angle of  $d\beta$  as [19]:

$$dC_{ic} = \epsilon_0 \cdot \epsilon_r \cdot d\beta \cdot \int_0^{l_{ts}} dh \int_{r_w}^{r_{w-ic}} \frac{r_{ic}}{dr_{ic}} \quad (3)$$

So we have:

**Fig. 8** View of the path  $g(\beta)$  of electric field lines  $E$  under angel  $\beta$  between two adjacent CWF in OTC of the generator [8]. a) View of  $g(\beta)$  path of electrical field lines under  $\beta$  angle. b) Two trapezium-shape regions 1 and 2 in ELBC.

- 1- Insulating coating region of the first CWF.
- 2- Insulating coating region of the second CWF.
- 3- Air gap region between two adjacent first and second CWFs in OTC.

Therefore, elementary capacitance of  $dC$  between adjacent CWF in OTC of the generator is equivalent to a series' combination of three elementary capacitors in three above regions. In other words, first capacitor is related to insulating coating of the first CWF, second capacitor is related to the air gap between two adjacent CWF, and third capacitor is related to insulating coating of the second CWF. Surfaces of CWF are considered co-potential by a relatively good approximation. As you can see, the direction of electric field lines between two adjacent CWF in OTC is in the radial form. By a good

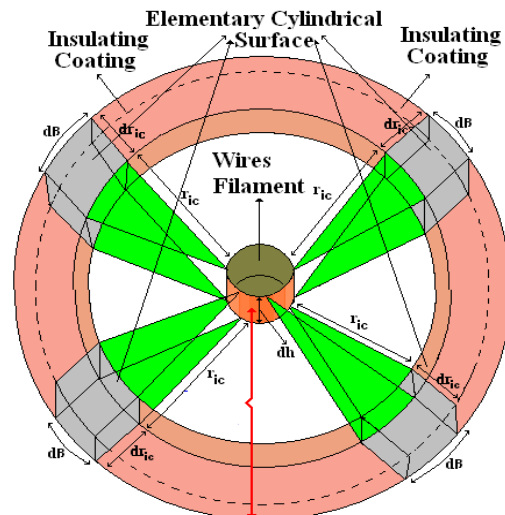

**Fig. 9** View of cylindrical elementary cross-section placed in insulating coating in non-real scale [8].

$$dC_{ic} = \varepsilon_0 \cdot \varepsilon_r \cdot \frac{l_{ts}}{\ln\left(\frac{r_{w-ic}}{r_w}\right)} d\beta. \quad (4)$$

Furthermore, since two insulating coating of two CWF in one turn of the coil are combined in series, so insulating coating elementary capacitance of a basic cell of two adjacent CWF with  $\beta$  angle will be:

$$\frac{1}{dC_{ic-ss}} = \frac{1}{dC_{ic}} + \frac{1}{dC_{ic}} = \frac{2}{dC_{ic}} \quad (5)$$

Therefore, elementary capacitance of insulating coating of a basic cell is:

$$dC_{ic \rightarrow ss} = \varepsilon_0 \cdot \varepsilon_r \cdot \frac{l_{ts}}{2 \cdot \ln\left(\frac{r_{w-ic}}{r_w}\right)} d\beta \quad (6)$$

As a result, by integrating of (6) over  $\beta$ , capacitance of insulating coating of two adjacent CWF in OTC of the generator is obtained by:

$$C_{ic \rightarrow ss}(\beta) = \varepsilon_0 \cdot \varepsilon_r \cdot \frac{l_{ts}}{2 \cdot \ln\left(\frac{r_{w-ic}}{r_w}\right)} \beta \quad (7)$$

### 3.3 Air Gap Capacitance ( $C_{ag}$ ) Between Two Adjacent CWF in OTC of the Generator

Considering Figs. 7 and 8, angles of  $\beta$  can be obtained from (8).

$$\cos(\beta) = 1 - \frac{g(\beta)}{D_{w-ic}} \quad (8)$$

Therefore, the length of electric field path which is a function of  $\beta$  angle will be:

$$g(\beta) = D_{w-ic} (1 - \cos(\beta)). \quad (9)$$

The area of elementary surface of the CWF with insulating coating and in the form of an elementary ring of length ( $l_{ts}$ ) (turn length of the CWF), will be:

$$ds = \frac{1}{2} \cdot l_{ts} \cdot D_{w-ic} d\beta. \quad (10)$$

Total capacitance of  $dC_{ag \rightarrow ss}$  related to the air gap between two adjacent CWF will be:

$$dC_{ag \rightarrow ss}(\beta) = \varepsilon_0 \cdot \frac{l_{ts} \cdot D_{w-ic}}{2g(\beta)} d\beta = \varepsilon_0 \cdot \frac{l_{ts}}{2(1 - \cos(\beta))} d\beta. \quad (11)$$

### 4 Calculation of Filament-Filament Capacitance ( $C_{ss}$ ) Between Two Adjacent CWF in OTC of the HFCG [8].

Since capacitances of two regions 1 and 2 between two adjacent CWF will be combined in parallel form, so we have:

$$dC_{ss}(\beta) = dC_{ss1}(\beta) + dC_{ss2}(\beta) = 2dC_{ss1}(\beta), \quad (12)$$

where,  $dC_{ss1}(\beta)$  is the total capacitance of region 1, and  $dC_{ss2}(\beta)$  is the total capacitance of region 2.

Since elementary capacitance of insulating coating

and elementary capacitance of air gap between two adjacent CWF of each two trapezoid shaped regions 1 or 2 are combined in series' form, so by considering (12), total capacitance between two adjacent CWF will be:

$$dC_{ss}(\beta) = 2dC_{ss1}(\beta) = \frac{dC_{ic \rightarrow ss} \cdot dC_{ag \rightarrow ss}(\beta)}{dC_{ic \rightarrow ss} + 2dC_{ag \rightarrow ss}(\beta)}. \quad (13)$$

Therefore by considering the effect of insulating coating, total filament-filament capacitances ( $dC_{ss}$ ) of two adjacent CWF in OTC of the HFCG is:

$$dC_{ss}(\beta) = \frac{\varepsilon_0 \cdot l_{ts}}{1 - \cos(\beta) + 2 \ln K1 \cdot \varepsilon_r^{-1}} d\beta \quad (14)$$

where  $K1 = \frac{D_{w-ic}}{D_w}$ .

### 5 Filament-Liner Capacitance Between one CWF in OTC and Liner [8]

To calculate filament-liner capacitance ( $C_{sl}$ ), first we use (5) to calculate the capacitance of insulating coating, which is placed between CWF and liner. Here we remind that we have only one insulating coating for calculating filament-liner capacitance. So we have:

$$dC_{ic \rightarrow sl} = dC_{ic} = \frac{\varepsilon_0 \cdot \varepsilon_r \cdot l_{ts}}{\ln\left(\frac{r_{w-ic}}{r_w}\right)} d\alpha. \quad (15)$$

Besides, path length of electric field lines in the air gap between the CWF and line of  $\psi$  which passes from the middle of coil turn is equal to  $Z$ . Also, the basic cell of the filament-liner capacitance is bigger and wider than the basic cell of filament-filament capacitance. A part of the perimeter of the CWF by an approximation and simplified assumptions is equal to an angle of  $2\pi/3$  radian. The basic cell of the filament-liner is placed in this angle (Fig. 8). Considering Figs. 7 and 8, the value of  $\alpha$  angle is:

$$\cos(\alpha) = 1 - \frac{2g(\alpha)}{D_{w-ic}}. \quad (16)$$

The area of elementary surface of the CWF which has been insulating coating and is in the form of an elementary ring of length ( $l_{ts}$ ) (turn length of the CWF), will be:

$$ds = \frac{1}{2} \cdot l_{ts} \cdot D_{w-ic} \cdot d\alpha. \quad (17)$$

Also, capacitance between the CWF and central cylindrical liner related to the air gap is:

$$dC_{ag \rightarrow sl} = \varepsilon_0 \cdot \frac{ds}{g(\alpha) + Z}, \quad (18)$$

where,  $dC_{ag \rightarrow sl}$  is total capacitance related to the region 3 of the air gap between the CWF and central cylindrical liner. So, by considering above explanations and equations (16), (17) and (18), the air gap



capacitance of filament-liner of region 3 is:

$$dC_{ag \rightarrow sl}(\alpha) = \frac{\epsilon_0 \cdot l_{ts} \cdot D_{w-ic}}{2(g(\alpha) + Z)} d\alpha \quad (19)$$

Since the capacitance between CWF and central cylindrical liner of two regions 3 and 4 are combined in the parallel form, we have:

$$C_{sl}(\alpha) = dC_{sl3}(\alpha) + dC_{sl4}(\alpha) = 2 \cdot dC_{sl3}(\alpha), \quad (20)$$

where  $dC_{sl3}(\alpha)$  is the total capacitance of region (3) and  $dC_{sl4}(\alpha)$  is the total capacitance of region (4) between CWF and central cylindrical liner and considering the geometrical symmetry of two regions 3 and 4 in Fig. 8, capacitances of these two regions are equal.

Considering the series' combination of the air gap elementary capacitance and insulating coating of trapezoid-shape region 3 or 4, then the total equivalent capacitance between CWF in the OTC and central cylindrical liner, with considering (20) is:

$$dC_{sl}(\alpha) = 2dC_{sl3}(\alpha) = \frac{dC_{ag \rightarrow sl} \cdot dC_{ic \rightarrow sl}}{dC_{ic \rightarrow sl} + 2dC_{ag \rightarrow sl}} \quad (21)$$

Therefore, we have:

$$dC_{sl}(\alpha) = 2\epsilon_0^2 \epsilon_r \cdot \frac{l_{ts}^2 \cdot D_{w-ic}}{K4 + (K5 \cdot [\epsilon_0 \epsilon_r l_{ts}])} d\alpha, \quad (22)$$

where  $K4 = (2\epsilon_0 \cdot D_{w-ic} \cdot l_{ts}) \cdot \ln(K1)$  and  $K5 = 2Z + D_{w-ic}(1 - \cos(\alpha))$ .

So  $C_{sl}(\alpha)$  will be:

$$C_{sl}(\alpha) = K10 \cdot \frac{\text{Arc tan} \left[ \frac{K9}{\sqrt{K6 + K7 + K8}} \cdot \frac{1}{\sqrt{3}} \right]}{\sqrt{K6 + K7 + K8}}, \quad (23)$$

where  $K6 = \epsilon_r^2 \cdot Z(D_{w-ic} + Z)$ ,  
 $K7 = D_{w-ic} \cdot \epsilon_r (D_{w-ic} + 2Z) \ln(K1)$ ,  
 $K8 = D_{w-ic}^2 \cdot \ln^2(K1)$ ,  
 $K9 = \epsilon_r (D_{w-ic} + Z) + (D_{w-ic} \cdot \ln(K1))$ , and  
 $K10 = 2\epsilon_0 \cdot \epsilon_r \cdot l_{ts} \cdot D_{w-ic}$ .

### 6 Calculation of Layer-Layer Capacitance in One Turn of the HFCG Coil

In order to calculate the layer-layer capacitance, first we can obtain SC between two layers and then SC of one complete turn compose of h-layers by using the resultant value of filament-filament capacitance ( $C_{ss}$ ) (see Fig. 10).

From (24) the SC of layer-layer in one turn can be calculated [17].

$$C_{ll} = \frac{(k+1)(2k+1)}{6k} \cdot l \cdot C_{ss} \quad (24)$$

So by using (23), we will have:

$$C_{ll} = \frac{\epsilon_0 \cdot \epsilon_r \cdot l^2 \cdot (k+1)(2k+1)}{6k} \times \frac{\text{Arc tan}(\tan(\pi/24)) \cdot \sqrt{\epsilon_r \cdot (\ln(k1))^{-1} + 1}}{2\sqrt{\epsilon_r \cdot \ln(k1) + (\ln(k1))^2}}$$

where  $l$  is the average length of one turn and  $k$  is the number of CWF in one turn of the HFCG coil.

Furthermore, by a good approximation, we can consider the length of one turn of the generator coil equal with the length of one turn of CWF (i.e.  $l_{ts}=l$ ).

Above calculation method will be worthwhile if the number of CWF is less than 10 in each layer of one turn, but for the larger number of CWF in each layer it is convenient to use simpler formulas for calculating layer-layer capacitance ( $C_{ll}$ ).

If the number of CWF in each layer be larger than 10, then the structure of one turn of the HFCG coil can be modeled as a coaxial cylindrical capacitor (see Fig. 11) or if the curvature radius  $r$  be larger, the structure of one turn of the HFCG coil can be modeled as a parallel plate capacitor (see Fig. 12). Thus, if the number of CWF in each layer be larger than 10, then by using the model of a coaxial cylindrical capacitor we will have:

$$C_{ll} = 2\pi \cdot \epsilon_0 \cdot \epsilon_r \cdot \frac{W}{\ln\left(\frac{r+d}{r}\right)} \quad (25)$$

If  $r$  be very large ( $r \rightarrow \infty$ ) then we will have:

$$C_{ll} = 2\pi \cdot \epsilon_0 \cdot \epsilon_r \times \frac{r \cdot W}{d} \quad (26)$$

We can consider  $r$  equal to  $D/2$  (i.e.  $r=D/2$ ) in one turn of the HFCG coil, so the value of stray self-capacitance between two layers ( $C_{ll}$ ) is:

$$C_{ll} = \pi \cdot \epsilon_0 \cdot \epsilon_r \times \frac{D \cdot W}{d}, \quad (27)$$

where  $D$  is the turn diameter,  $W$  is the width of each layer (width of each turn having the rectangular cross-section) and  $d$  is the distance between two layers of the HFCG coil turns.

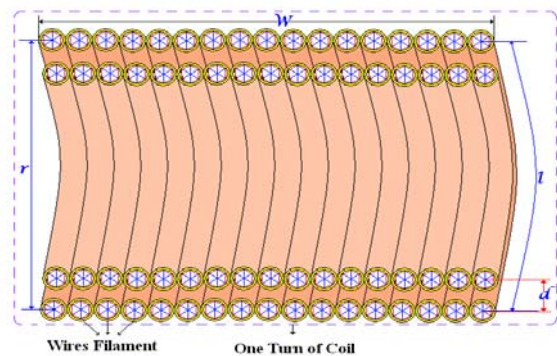

**Fig. 10** A cut of one turn cross-section of the HFCG coil included multi-layer of circular CWF in the form of (arrangement) rectangular cross-section.

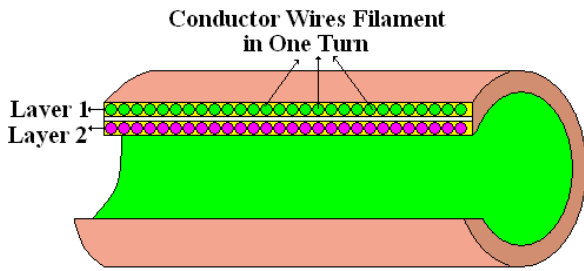

Fig. 11 A model of a coaxial cylindrical capacitor

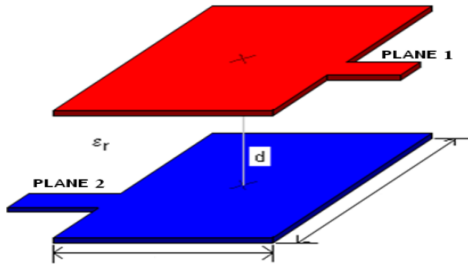

Fig. 12 A model of a parallel plate capacitor.

Finally, for stray self-capacitance of one complete turn with k-CWF includes the h-layer in the arrangement of rectangular cross-section, we will have:

$$C_t = 4C_{ll} \times \frac{(h-1)}{h^2}. \quad (28)$$

### 7 Calculation of Turn-Turn Capacitance of the HFCG

In this paper, cross-section of each CWF existing in each turn can be considered as a circle, which is wound around the central cylindrical conductor liner uniformly. The cross-section of each turn is rectangular; which is consisting of k-CWF (Figs. 13 and 14). In order to analyze and discuss the capacitance between two turns of the HFCG coil, first we should obtain filament turn-filament turn ( $C_{stst}$ ) capacitance between two CWF of two adjacent turns. We can consider the capacitance between two CWF of two adjacent turns equal to capacitance of per unit length of two straight parallel conductors with infinite length placed in a homogenous medium with neglecting the bend and curvature of turns. The thickness ( $t$ ) of insulating coating is small in compared with the air gap (distance between centers of two CWF of two adjacent turns) ( $p - 2r_{w-ic}$ ); so we can present analytical method to calculate filament turn-filament turn capacitance ( $C_{stst}$ ) of CWF with circular cross-section [11].

To obtain a proper relation for equivalent stray capacitance of coil, first we consider capacitance related to insulating coating and capacitance related to the air gap between CWF as a series' combination in the equivalent circuit. Using formula of cylindrical model capacitance, capacitance ( $C_{ic}$ ) between two CWF related to insulating coating is:

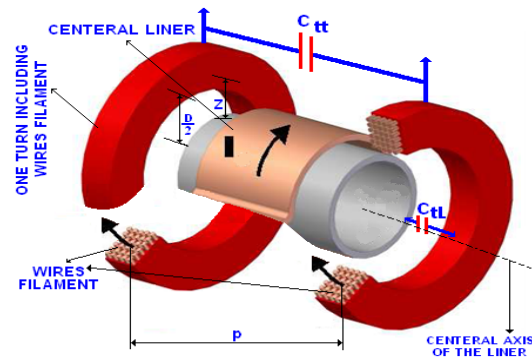

Fig. 13 Two adjacent turns which have k-CWF include circular cross-section, in the rectangular cross-section.

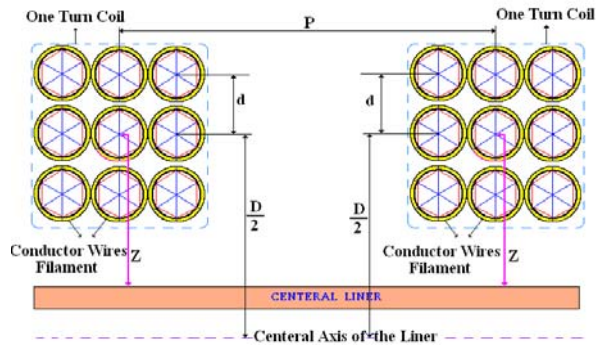

Fig. 14 Rectangular cross-section of two adjacent turns that each turn has K-CWF with circular cross-section.

$$C_{ic} = \frac{2\pi \cdot \epsilon_r}{\ln \left( 1 + \frac{2t}{D_w} \right)}. \quad (29)$$

For capacitance  $C_{ag}$  related to the air gap, we have:

$$C_{ag} = \frac{\pi \cdot \epsilon_0}{\ln \left[ \left( \frac{p}{D_{w-ic}} + \sqrt{\left( \frac{p}{D_{w-ic}} \right)^2 - 1} \right) \right]}, \quad (30)$$

where  $D_{w-ic}$  is the sum of CWF diameter and insulating coating,  $D_w$  is the circular cross-section diameter of CWF, and  $p$  is the winding pitch.

Moreover, because of existing two insulating coating related to two CWF of two adjacent turns, which are combined in series' form, we have:

$$C_{ic \rightarrow stst} = \frac{C_{ic}}{2} = \frac{\pi \cdot \epsilon_r}{\ln \left( 1 + \frac{2t}{D_w} \right)}, \quad (31)$$

where  $C_{ic \rightarrow stst}$  is the sum of capacitances related to two insulating coating of two CWF of two adjacent turns. Thus, the equivalent capacitance with the sum of series' combination of the air gap and insulating coating of these two CWF of two adjacent turns will be:

$$C_{stst} = \frac{C_{ic \rightarrow stst} \cdot C_{ag}}{C_{ic \rightarrow stst} + C_{ag}} = \frac{C_{ic} \cdot C_{ag}}{C_{ic} + 2C_{ag}}, \quad (32)$$

where  $C_{stst}$  is the capacitance between two CWF of two adjacent turns. Hence with replacing equations (29) and (30) in (32) for calculating the capacitance between two CWF of two adjacent turns and with these assumptions that thickness of an insulating coating ( $t$ ) has relative permittivity  $\epsilon_r$  and the direction of electric field in insulating coating ( $t$ ) is in the form of radial, we have:

$$C_{stst} = \frac{\pi^2 \cdot \epsilon_0 \cdot D}{\ln \left( A + \sqrt{A^2 - \left( \frac{D_{w-ic}}{D_w} \right)^{2\epsilon_r}} \right)}, \quad (33)$$

where  $A = \frac{p}{D_w \cdot \left( 1 - \frac{2t}{D_w} \right)^{(1-\epsilon_r)}}$

Because each turn has k-CWF and with supposing that distance of the CWF in the first turn from all CWF in the second turn is similar and equal to  $p$ , so by these assumptions and according to the superposition principle, there are  $K^2$  filament turn-filament turn capacitances ( $C_{stst}$ ) between two adjacent turns. Considering the series' combination of filament turn-filament turn capacitances ( $C_{stst}$ ) related to k-CWF of two adjacent turns, the total capacitance between two adjacent turns resulted from k-CWF will be:

$$\frac{1}{C_{tt}} = \frac{1}{C_{stst}} + \frac{1}{C_{stst}} + \dots + \frac{1}{C_{stst}} = \frac{k^2}{C_{stst}} \quad (34)$$

Therefore we have:

$$C_{tt} = \frac{C_{stst}}{k^2} = \frac{\pi^2 \cdot \epsilon_0 \cdot D}{k^2 \cdot \ln \left[ \frac{p}{Q} + \sqrt{\left( \frac{p}{Q} \right)^2 - \left( \frac{D_{w-ic}}{D_w} \right)^{2\epsilon_r}} \right]}, \quad (35)$$

where  $Q = D_w \cdot \left( 1 - \frac{2t}{D_w} \right)^{(1-\epsilon_r)}$

### 8 Stray Capacitance Between a Turn Include k-CWF and Liner

We can obtain capacitance between a turn with k-CWF and liner. By considering that the previous simplified assumptions and the thickness of insulating coating ( $t$ ) of CWF, which is small in comparing with the air gap ( $z$ ); we can obtain capacitance between conductor wire filament and liner ( $C_{sl}$ ). Besides, it was assumed that each turn has k-CWF in parallel combination. So, total capacitance of one turn is:

$$C_{tl}(\alpha) = C_{sl} + C_{sl} + C_{sl} + \dots = kC_{sl} \quad (36)$$

Therefore, we have:

$$C_{tl} = k \cdot K10 \cdot K6 \times \frac{\text{Arc tan} \left[ \frac{K9}{\sqrt{K6 + K7 + K8}} \times \frac{1}{\sqrt{3}} \right]}{\sqrt{K6 + K7 + K8}}, \quad (37)$$

where  $K6 = \epsilon_r^2 \cdot Z(D_{w-ic} + Z)$ ,  
 $K7 = D_{w-ic} \cdot \epsilon_r (D_{w-ic} + 2Z) \ln(K1)$ ,  
 $K8 = D_{w-ic}^2 \cdot \ln^2(K1)$ ,  
 $K9 = \epsilon_r (D_{w-ic} + Z) + (D_{w-ic} \cdot \ln(K1))$ ,  
 $K10 = 2\epsilon_0 \cdot \epsilon_r \cdot l_{ts} \cdot D_{w-ic}$

where  $C_{tl}$  is the capacitance between turn and liner.

### 9 Total Stray Capacitance of the HFCG

In order to obtain the total SC of the HFCG, according to Fig. 15, we can calculate the total SC of  $C(n)$  for  $n$  adjacent turns, including multi-layer that each turn has k-CWF in rectangular cross-section [15]. A network as shown in Fig. 16 can describe the total stray capacitance  $C_{tt}$  and  $C_{tl}$  for each turn. So equivalent circuit can be modeled by the total SC network of  $C(n)$  [16].

Cylindrical conductor liner can be considered as a node that turn-liner capacitance ( $C_{tl}$ ) is connected to this node. For NTC of the generator that each turn is composed of many CWF, we consider two adjacent turns among the turns of the generator coil that for these two turns ( $n=2$ ). Capacitance of network, consists of capacitance ( $C_{tt}$ ) between two turns 1 and 2 in parallel with the series' combination of the turn-liner capacitances ( $C_{t(1)l}$ ) and ( $C_{t(2)l}$ ), where  $C_{t(1)l} = C_{t(2)l} = C_{tl}$ , which  $C_{t(1)l}$  and  $C_{t(2)l}$  are capacitance between turns 1 and 2 with central cylindrical liner of the generator respectively.

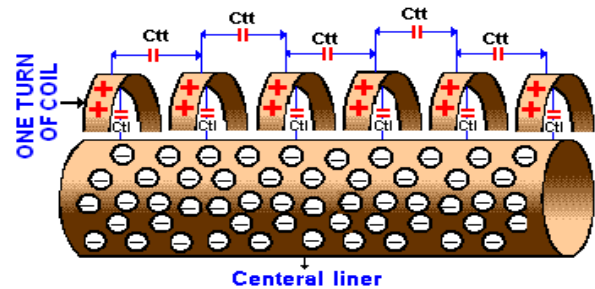

Fig. 15 Geometrical space of  $n$  turns include multi-layer with k-CWF and cylindrical liner placed at the center of coil turns and turn-turn parasitic capacitance ( $C_{tt}$ ) and turn-liner parasitic capacitance ( $C_{tl}$ ) in non-real scale.

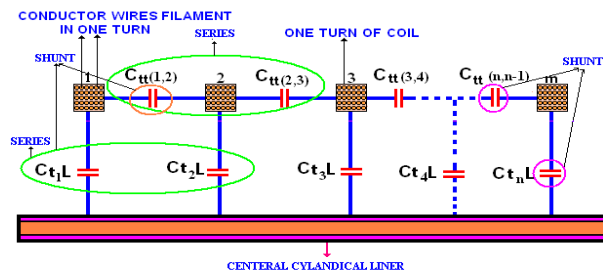

Fig. 16 Lump capacitors of  $n$  turn having CWF multi-layer in rectangular cross-section of the HFCG turns in non-real scale.



So, equivalent capacitance of these two adjacent turns is:

$$C(n=2) = C(1,2) = C_{tt} + \frac{C_{tl}}{2}. \quad (38)$$

For more turns, first we consider three adjacent turns of the HFCG coil. Equivalent capacitance of this capacitor network with three turns ( $n=3$ ) can be obtained by splitting capacitance ( $C_{t(2)i}$ ) into two halves and applying the  $\Delta/Y$  transformations (Fig. 17).

So, we have:

$$C(n=3) = C(1,2,3) = \frac{C_{tt}}{2} + \frac{C_{tl}}{2}. \quad (39)$$

In order to obtain total capacitance of four turns composed of  $k$ -CWF in turns, we can consider one more turn beside of three turns. So, total capacitance is equal to capacitance of previous arrangement (i.e. two turns), which is in series' form with turn-turn capacitance and parallel to the series' combination of turn-liner capacitance. Therefore, for  $n=4$ , we have:

$$C(n=4) = C(1,2,3,4) = \frac{C_{tt} \cdot C(2)}{C_{tt} + 2C(2)} + \frac{C_{tl}}{2}. \quad (40)$$

In order to obtain the total capacitance of  $n$  turns, we can add one turn to previous turns in each time. Therefore, total stray capacitance of the HFCG with any number of turns can be calculated by the mentioned method. So, for coil of the HFCG composed of  $n$  turns having the multi-layer, where each turn has  $k$ -CWF in itself, we have:

$$C(n) = \frac{C_{tt} \cdot C(n-2)}{C_{tt} + 2C(n-2)} + \frac{C_{tl}}{2}, \quad (41)$$

where,  $C(n-2)$  is the stray capacitance of  $(n-2)$  the turns of the HFCG coil composed of  $k$ -CWF and  $n$  is the total number of turns existing in the generator coil.

## 10 Results of Simulations

Considering Fig. 18, Fig. 19, and Fig. 20 resulted from simulation related to the total capacitance  $C(n)$  of the HFCG, we see that by progress of the explosion, extension of the liner, and decrease the number of the HFCG coil turns, total capacitance of the HFCG will be increased. This incremental of capacitance will continue until the number of turns existing in circuit decrease to two turns. However, it was seen that when only one turn remained in the circuit, there occurs a descending decrease in the total capacitance of the generator, because there is only one remained turn in the circuit, and we have only turn-liner capacitance.

From Figs. 15 and 17, it was clearly seen that the total stray capacitance of NTC of the HFCG will be increased by increasing of the turn length ( $l_{ts}$ ), the cross-section diameter ( $D_w$ ), the number of CWF ( $k$ ), and by decreasing of the winding pitch ( $p$ ).

So by considering the above results, to decrease total stray capacitance of  $n$  turns of the HFCG coil, we should:

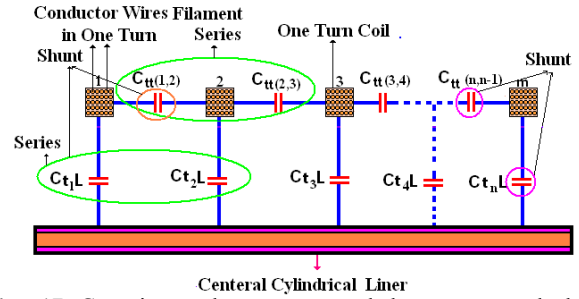

Fig. 17 Capacitance between wound turns around the central liner.

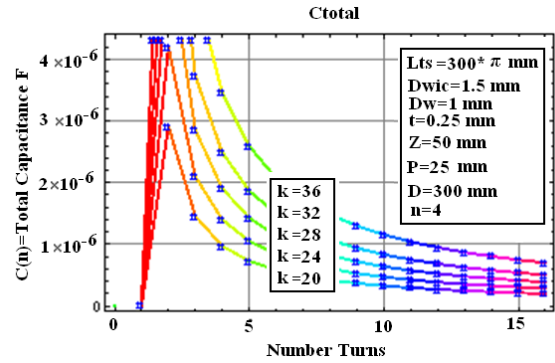

Fig. 18 Total capacitance of the HFCG for different numbers of CWF existing in turns.

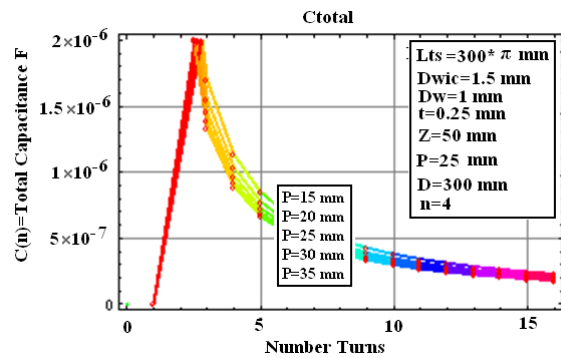

Fig. 19 Total capacitance of the HFCG for different winding pitches.

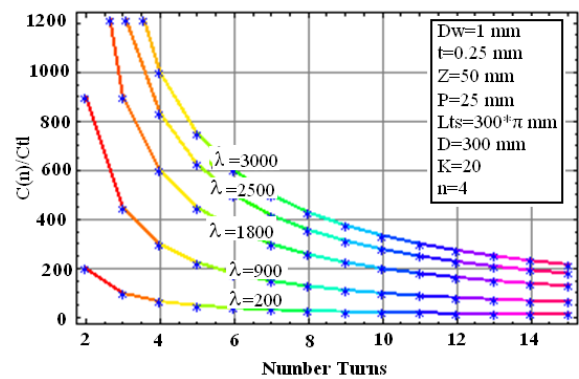

Fig. 20 Ratio of total capacitance of nTC of the generator to turn-liner capacitance  $C(n)/C_{tl}$  for different values of  $\lambda$ .

- Decrease the number of CWF in turns as much as possible.
- Decrease turns length of CWF in turns.
- Decrease winding pitch of the coil turns.
- Increase the diameter of the cross-section of CWF in turns of the HFCG coil.

Use coils with single-layer cross-section no multi-layer cross-section.

### 11 Calculation and Study of Sensitivity Coefficients Ratio

To obtain the ratio of stray capacitance  $C(n)$  of  $n$  turns with  $k$ -CWFs include multi-layer to the stray capacitance of the turn-liner ( $C_{tl}$ ), with considering (41), we will have:

$$\frac{C(n)}{C_{tl}} = \frac{C_{tt}}{C_{tl}} \times \frac{C(n-2)}{C_{tt} + 2C(n-2)} + \frac{1}{2} \quad (42)$$

If we assume  $C_{tt}/C_{tl} = \lambda$  then  $C(n)/C_{tl}$  ratio will be:

$$\frac{C(n)}{C_{tl}} = \lambda \times \frac{C(n-2)}{C_{tt} + 2C(n-2)} + \frac{1}{2} \quad (43)$$

For large amounts of  $n$ , convergence of (43) to a proper region is shown in Fig. 20. We see that convergence of (43) for small amounts of  $\lambda$  will be more rapid, by increasing the number of turns. So, by increasing the number of coil turns, the ratio of  $C(n)/C_{tl}$  will be smaller and more convergent and for smaller values of  $\lambda$ , the total stray capacitance of the MCG is lower.

Considering the obtained relations in the last section, if we want to obtain the ratio of total stray capacitance ( $C(n)$ ) of  $n$  turns with  $k$ -CWFs of the MCG coil to turn-turn stray capacitance ( $C_{tt}$ ), with respect to (43), we will have:

$$\frac{C(n)}{C_{tt}} = \frac{C(n-2)}{C_{tt} + 2C(n-2)} + \frac{1}{2} \times \frac{C_{tl}}{C_{tt}} \quad (44)$$

If we assume  $C_{tl}/C_{tt} = \delta$ , then  $C(n)/C_{tt}$  ratio will be:

$$\frac{C(n)}{C_{tt}} = \frac{C(n-2)}{C_{tt} + 2C(n-2)} + \frac{1}{2} \times \delta \quad (45)$$

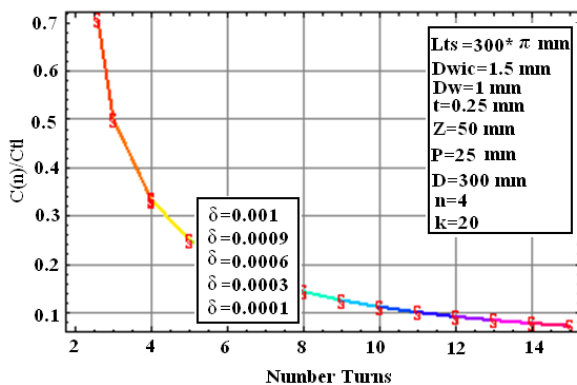

Fig. 21 Ratio of total capacitance of  $n$  turns to turn-turn capacitance  $C(n)/C_{tt}$  for different values of  $\delta$ .

Convergence of (45) to a proper region is shown in Fig. 21 for large amounts of  $n$ . We see that variations of  $\delta$  values have no effect on the obtained results. For smaller  $\delta$  value and more turn's number,  $C(n)/C_{tt}$  ratio is smaller and total stray capacitance of the MCG is lower.

### 12 Numerical Calculation Results of Total Capacitance of the HFCG in Presented Method

The HFCG coil in this study has 4-layers, 16-turns, and 24-CWF (i.e.  $k=24$ ). Several groups of CWF with different diameters, cross-section, and lengths of turn are used in order to show the results of presented method. Geometrical parameters of CWF and their results are presented in Tables 1-4. We see that diameter of CWF of each turn, kind of insulating coating with relative permittivity ( $\epsilon_r$ ), distance of turn from liner, thickness of insulating coating, turn length of CWF, and winding pitch have effect on capacitance between turns ( $C_{tt}$ ) and capacitance between turn and liner ( $C_{tl}$ ).

The results show that the calculated capacitance for coils with different winding pitches is a function of the number of turns. In other words, by increasing the winding pitch, capacitance between turns will be decreased.

Furthermore, it was seen that the diameter of turns, radius of circular cross-section, winding pitch, radius of insulating coating and kind of insulating coating ( $\epsilon_r$ ) have the effect on turn-turn capacitance ( $C_{tt}$ ). However, the air gaps between the turns and central cylindrical liner have the effect on turn-liner capacitance ( $C_{tl}$ ), the loss energy, and stray capacitance.

### 13 Verification of the results

In this paper in order to examine and study the results' accuracy, the proposed method for calculate the stray capacitance is compared with the results of reference [19].

Table 1 Geometrical parameters and results of theory of calculation turn-turn capacitance with circular cross-section of CWF having insulating coating in the rectangular cross-section.

	D(mm)	Dw (mm)	t(mm)	K	P(mm)	Ctt ( $\mu$ F)
D <sub>w</sub>	300	0.5	0.25	24	25	3.712
	300	0.75	0.25	24	25	4.405
	300	1	0.25	24	25	4.599
t	300	1	0.15	24	25	4.328
	300	1	0.2	24	25	4.467
	300	1	0.25	24	25	4.599
p	300	1	0.25	24	30	4.357
	300	1	0.25	24	25	4.599
	300	1	0.25	24	20	4.937
D	350	1	0.25	24	25	5.366
	300	1	0.25	24	25	4.599
	250	1	0.25	24	25	3.833
K	300	1	0.25	32	25	8.177
	300	1	0.25	28	25	6.261
	300	1	0.25	24	25	4.599

**Table 2** Geometrical parameters and results of theory of calculation turn-liner capacitance with circular cross-section of CWF having insulating coating in rectangular cross-section

	D(mm)	D <sub>w</sub> (mm)	t(mm)	K	Z(mm)	C <sub>tl</sub> (nF)
D <sub>w</sub>	300	0.5	0.25	24	60	<b>1.739</b>
	300	0.75	0.25	24	60	<b>1.310</b>
	300	1	0.25	24	60	<b>1.747</b>
t	300	1	0.15	24	60	<b>1.746</b>
	300	1	0.2	24	60	<b>1.746</b>
	300	1	0.25	24	60	<b>1.747</b>
Z	300	1	0.25	24	50	<b>2.096</b>
	300	1	0.25	24	60	<b>1.747</b>
	300	1	0.25	24	70	<b>1.497</b>
D	350	1	0.25	24	60	<b>2.038</b>
	300	1	0.25	24	60	<b>1.747</b>
	250	1	0.25	24	60	<b>1.455</b>
K	300	1	0.25	32	60	<b>2.329</b>
	300	1	0.25	28	60	<b>2.038</b>
	300	1	0.25	24	60	<b>1.747</b>

**Table 3** Geometrical parameters and results of theory of calculation total stray capacitance of the generator with circular cross-section of 24-CWF having insulating coating in rectangular cross-section in constant frequency of 100KHZ

D=300 (mm) , F=100 (kHz) , Z=60 (mm) , P=25 (mm), D <sub>w</sub> =1(mm) , t=0.25 (mm) K=24, n(l)=4		
Number turns	C[m] (nF)	Xc[m] (Ω)
16	283.77	<b>5.608</b>
15	303.54	<b>5.243</b>
14	326.39	<b>4.876</b>
13	353.09	<b>4.507</b>
12	384.67	<b>4.137</b>
11	422.62	<b>3.765</b>
10	469.05	<b>3.393</b>
9	527.13	<b>3.019</b>
8	601.88	<b>2.644</b>
7	701.62	<b>2.268</b>
6	841.33	<b>1.891</b>
5	1051.0	<b>1.514</b>
4	1400.6	<b>1.136</b>
3	2100.0	<b>0.757</b>
2	4198.8	<b>0.379</b>
1	2.6088	<b>610.0</b>

**Table 4** Geometrical parameters and results of theory of calculation total stray capacitance of the generator with circular cross-section of 24-CWF having insulating coating in rectangular cross-section with variable incremental voltage.

D=300 (mm) , Z=60 (mm) , P=25 (mm), D <sub>w</sub> =1(mm) , t=0.25 (mm) K=24, n(l)=4			
Number turns	Voltage (kv)	C[m] (nF)	Wc[m] (j)
16	1	283.77	<b>0.141</b>
15	1.5	303.54	<b>0.341</b>
14	2	326.39	<b>0.652</b>
13	2.5	353.09	<b>1.103</b>
12	3	384.67	<b>1.731</b>
11	3.5	422.62	<b>2.588</b>
10	4	469.05	<b>3.752</b>
9	4.5	527.13	<b>5.337</b>
8	5	601.88	<b>7.523</b>
7	5.5	701.62	<b>10.61</b>
6	6	841.33	<b>15.14</b>
5	6.5	1051.0	<b>22.20</b>
4	7	1400.6	<b>34.31</b>
3	7.5	2100.0	<b>59.06</b>
2	8	4198.8	<b>134.3</b>

Because of limitations and problems of the MCG explosion and problems of the measurements of the inductance and resistance and parasitic capacitance of MCG generator, we assume that the MCG generator has one turn with parameters as follows:

$$D_{w-ic} = 49.5 \times 10^{-2} \text{ mm}, \quad D_w = 45 \times 10^{-2} \text{ mm},$$

$$t = 22.5 \times 10^{-2} \text{ mm}, \quad \epsilon_r = 3.5, \quad \epsilon_0 = 8.85 \times 10^{-12},$$

$$\beta = \frac{\pi}{6}, \quad l_{ts} = 4.4925.10 \text{ mm}, \quad Z = 50 \text{ mm}.$$

By using the equation (24) from [19] and with considering to above mention characteristics capacitance  $C_{ss}$  will be:

$$C_{ss} = \int_0^{\pi/6} \frac{8.85 \times 10^{-12} \times 4.4925.10^{-2}}{1 - \cos(\beta) + \left( 2 \times \ln \left( \frac{49.5 \times 10^{-2}}{45 \times 10^{-2}} \right)^{(3.5)^{-1}} \right)^{d\beta}}$$

$$C_{ss} = 3.894 \text{ PF}$$

Also by using the results of relation (14) in this paper with same above parameters, the stray capacitance  $C_{SS}$  will be as follow:

$$C_{SS} = 3.851 \text{ PF}.$$

So we can see that the filament-filament capacitance  $C_{ss}$  obtain by equation (14) is same as filament-filament capacitance  $C_{SS}$  which obtained from equation (24) in reference [19].

## 14 Conclusions

In this paper, we used the VRH model, in order to calculate stray capacitance between multilayer of CWF in OTC, between the turns of the coil, and between turn and central cylindrical liner of the HFCEG. The presented method is applied to calculate the stray capacitance of multi-layer coils, including CWF in rectangular cross-section form. It was seen that the number of CWF existing in turns of the coil has the effect on total stray capacitance of the HFCEG. The results show that in order to decrease the total stray capacitance of the generator, we should decrease the radius of circular cross-section, diameter of the coil turns and the number of CWF. Also the air gap between the turns of the coil, the central cylindrical liner, winding pitch, thickness of insulating coating of the coil should be increased. It was seen that by progress of the explosion and volume extension of the liner, the number of turns of the generator coil decreased and total capacitance of the generator increased. However, from simulation results were clearly seen that, when only one turn remains in the circuit, there occurs a descending decrease in total capacitance of the generator, and it is because of remaining only one turn in the circuit. In the last turn,

by progress of the explosion, turn length decreases. Hence effective cross-section between turn and liner decreases and finally capacitance between turn and liner will be decreased. Furthermore, it was seen that the value of reactance, which is produced from the total stray capacitance of the HFCG will be reduced by progress of explosion and reduction of the coil turns. The reactance has the minimum value in the second remaining end turn of the circuit, but the value of reactance will go to increase in the end ring, because of reduction of stray capacitance in the end ring.

## References

- [1] Neuber A. A., *Explosively Driven Pulsed Power Helical Magnetic Flux Compression Generators*, 1nd ed. Vol. 1, New York: Springer-Verlag, 2005.
- [2] Altgiberts L. L., Brown M. D. J., and Novac B. M., *Magneto Cumulative Generators*, 1nd ed. Vol. 1, New York, USA: Springer-Verlag, 2000.
- [3] Boriskov G. V., Bykov A. I., Dolotenko M. I., Egorov N. I. and Timareva V. I., "On one possibility of cascade MC-1 generator final-magnetic field increasing", *Elsevier, Physica B* 294-295, pp.665-668, 2001.
- [4] Tatsenko O. M., Platonov V. V., Bykov A. I., Dolotenko M. I., Zvezdin A. K., Solem J. C., Fowler C. M., Goettee J. D., Rickel D., Campbell L. J., Veaser L., Sheppard M., Gallegos C. H. and Marshall B., "Quantum jumps in magneto-optical effects and magnetization of rare-earth compounds in ultrahigh magnetic fields", *Elsevier, Physica B* 246-247, pp. 315-318, 1998.
- [5] Takeyama S., Osada T. and Miura N., "Solid-state physics towards pulsed ultra-high magnetic fields at ISSP", *Elsevier, Physica B* 346-347, pp. 576-581, 2004.
- [6] Bykov A. I., Dolotenko M. I., Kolokolchikov N. P., Selemir V. D. and Tatsenko O. M., "VNIIEF achievements on ultra-high magnetic fields generation", *Elsevier, Physica B* 294-295, pp. 574-578, 2001.
- [7] Mosleh M. E. and Besmi M. R., "Sensitivity analysis of effective parameters in stray capacitance of magneto cumulative generator having integrated rectangular cross-section turns, with insulating coating", *International Review of Electrical Engineering (IREE)*, Vol. 6, No. 1, pp. 275-284, January-February 2011.
- [8] Mosleh M. E. and Besmi M. R., "Calculation of stray capacitance of MCG coil include one turn, single-layer and conductor wire filaments in rectangular form", *Iranian Journal of Electrical & Electronic Engineering*, Vol. 7, No. 1, pp. 19-27, March 2011.
- [9] Yu Q., "RF Equivalent circuit modeling of ferrite-core inductors and characterization of core materials", *IEEE Trans. Electromagnetic Compatibility*, Vol. 44, No. 1, pp. 258-262, Feb. 2002.
- [10] Bartoli M., Reatti A. and Kazimierczuk M. K., "Modeling of iron powder inductors at high frequencies", in *Proc. IEEE Industry Applications Conf. Denver, Co*, pp.1225-1232. 1994.
- [11] Grandi G., "Stray capacitances of single-layer air-core inductors for high-frequency applications", *IEEE Trans. Industry applications*, Vol. 35, No. 5, pp. 1162-1165, Sep./Oct 1999.
- [12] Yu Q. and Holmes T. W., "A Study on stray capacitance modeling of inductors by using the Finite Element method", *IEEE Trans. Electromagnetic Compatibility*, Vol. 43, No. 1, pp.88-93, Feb. 2001.
- [13] Massarini A., "Self-capacitance of inductors", *IEEE Trans. Power Electronics*, Vol. 12, No. 4, pp. 671-676, July 1997.
- [14] Chen R., Van Wyk J. D., Wang S. and Odendaal W. G., "Application of structural winding capacitance cancellation for integrated EMI filters by embedding conductive layers", in *Proc. Ind. Appl. Soc.*, pp. 2679-2686, 2004.
- [15] Lu H., "Experimental determination of stray capacitances in high frequency transformers", *IEEE Trans. Power Electronics*, Vol. 18, No. 5, pp.1105-1112, Sep. 2003.
- [16] Dalessandro L., Silveira F. and Kolar J. W., "Self-Capacitance of High-Voltage Transformers", *IEEE Trans. Power Electronics*, Vol. 22, No. 5, pp. 2081-2092, 2007.
- [17] Faghihi F. and Heydari H., "Mathematical proof for the minimized stray fields in transformers using auxiliary windings based on state equations for evaluation of FEM results", *Iranian Journal of Electrical & Electronic Engineering*, Vol. 6, No. 1, pp. 62-69, March 2010.
- [18] Yaghobi H., Ansari K. and Rajabi Mashhadi H., "Analysis of magnetic flux linkage distribution in salient-pole synchronous generator with different kinds of inter-turn winding faults", *Iranian Journal of Electrical & Electronic Engineering*, Vol. 7, No. 4, pp. 260-272, Dec. 2011.
- [19] Kostenko M. and Piotrovsky L., *Electrical Machines*, Vol. 1. Moscow, Russia: Mir, 1968.



**Majid Ezati Mosleh** was born in Tehran, Iran, in 1981. He is a Member of IAEEE in 2005 in Iran. He received the B.S. degree in electrical engineering from Electronic Technical University of Shiraz, Iran, in 2005 and the M.S. degree in electrical engineering from Shahed University in 2009. His research interests are in

high-frequency machines, magneto cumulative generators, magnetic. He has two inventions and several country award of Iran. He has published several books and papers in electronics engineering.





**Mohammad Reza Besmi** was born in Tehran, Iran, in 1959. He received the B.S. degree in electrical engineering from Amirkabir University, Iran, in 1989, the M.Tech degree in electrical engineering from University of Indian Institute of Technology, Delhi in June 1992 and the Ph.D. degree in electrical engineering from Newcastle upon

Tyne University in September 1996. From 1997 to 1999, he was with the Niroo Research Institute in Iran. He is currently Assistant Professor of Electrical Engineering Department and head of power group at Shahed University. His current research work is in special electrical machine design.