

A new fuzzy-based maximum power point tracker for photovoltaic applications

M. A. S. Masoum and M. Sarvi

Abstract: A new fuzzy maximum power point tracker (MPPT) for photovoltaic systems is proposed. Fuzzy controller input parameters dP/dI , $\Delta(dP/dI)$ and variation of duty cycle (ΔDC) are used to generate the optimal MPPT converter duty cycle, such that solar panel maximum power is generated under different operating conditions. A photovoltaic system including a solar panel, a fuzzy MPP tracker and a resistive load is designed, simulated and constructed. The fuzzy MPP tracker includes a buck dc/dc converter, fuzzy controller and interfacing circuits. Theoretical and experimental results are used to indicate the advantages and limitations of the proposed technique.

Keywords: photovoltaic, maximum power point tracker, insolation and fuzzy.

1 Introduction

Applications of photovoltaic (PV) energy have increased significantly over the past decade. This is mainly due to the rapid depletion of conventional energy resources and the broad availability of solar radiation.

Photovoltaic power is considered as a prime candidate of energy in many countries with high solar power density. The photovoltaic system technologies are rapidly expanding with an increasing role in electric power technologies, providing pollution free and secure power sources. These applications include water pumping, refrigeration and vaccine storage, air conditioning, light sources, electric vehicles, PV power plants, hybrid systems, military and space applications.

PV systems are dependent power sources with nonlinear I-V characteristics under different environmental (insolation, temperature, degradation) conditions. In addition they have high fabrication cost and low energy conversion efficiency. These are the main reasons for the low electrical efficiency of photovoltaic systems. To overcome these problems, the maximum power point of the PV system (at a given condition) is tracked using on-line or off-line algorithms and the system operating point is forced toward this optimal condition.

In the literature, many maximum power point tracking (MPPT) techniques are proposed and implemented. These techniques include look-up table methods [1-2], perturbation and observation (P&O) methods [3-4] and computational methods [5-7]. One of the computational methods which has demonstrated fine performances under different environmental operating conditions is the fuzzy-based MPPT technique [8-9].

The fuzzy theory based on fuzzy sets and fuzzy algorithms provides a general method of expressing linguistic rules so that they may be processed quickly by a computer. Recently the application of fuzzy control has been successful in photovoltaic applications [8-19]. The fuzzy controller introduced in [8] uses dP/dI and its variations $\Delta(dP/dI)$ as the inputs and computes

MPPT converter duty cycle. The shortcoming of this approach is the ignorance of duty cycle variations, which results in an acceptable accuracy level with poor dynamic characteristics (Fig.11 of [8]). The fuzzy tracker of reference [9] considers variation of duty cycle, but replaces dP/dI by the variation of panel power. This tracker has fine dynamic behavior with limited accuracy (Fig.21 of [9]).

This paper presents a fuzzy-based MPP tracker, which uses a combination of fuzzy logic presented in references [8] and [9]. A photovoltaic system including a solar panel, a fuzzy MPP tracker and a resistive load is designed, simulated and constructed. Simulated and measured results are presented.

2 The photovoltaic system

Using the equivalent circuit of Fig.1, the nonlinear I-V characteristics of solar cells is given by the following equation:

$$i_{SA} = I_{ph} - I_o \left\{ \exp \left(\frac{q}{AKT} (v_{SA} + R_S i_{SA}) \right) - 1 \right\} \quad (1)$$

where v_{SA} and i_{SA} are the output voltage and current of the solar cell, respectively, I_{ph} is the generated current under a given insolation, I_o is the reverse saturation current, q is the charge of an electron, A is the ideality factor for a p-n junction, K is the Boltzmann's constant, T is the temperature and R_S is the series resistance of the solar cell. By rearranging the terms of Eq.1, the nonlinear V-I characteristic of solar cells is:

$$v_{SA} = \frac{AKT}{q} \ln \left(\frac{I_{ph} - i_{SA} + I_o}{I_o} \right) - R_S i_{SA} \quad (2)$$

Using Eq.2, the nonlinear V-I characteristics of a solar panel with M parallel strings and N series cells per string is:

$$v_{SA} = \frac{N}{\lambda} \ln \left(\frac{I_{ph} - i_{SA} + MI_o}{MI_o} \right) - \frac{N}{M} R_S i_{SA} \quad (3)$$

where λ is a constant coefficient (q/AKT) that depends on cell material and temperature.

For the silicon solar panel ($M=1$, $N=36$) used for theoretical and experimental analysis of this paper (Table 1, manufactured by the Iranian Optical Fiber Fabrication Co. (OFFC)), Eq.3 can be written as:

Iranian Journal of Electrical & Electronic Engineering, 2005.

Paper first received 26th October 2002 and in revised form 6th January 2004.

M. A. S. Masoum is with the Department of Electrical Engineering, Iran University of Science and Technology, Narmak, Tehran 16844, Iran.

M. Sarvi is with Advanced Electronic Research Center, Tehran, Iran.

$$v_{SA} = 1.767 \ln \left(\frac{I_{ph} - i_{SA} + 0.00005}{0.00005} \right) - i_{SA} \quad (4)$$

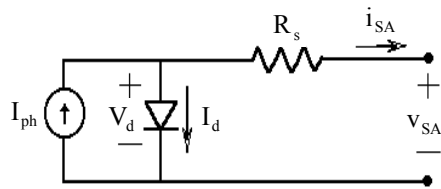

Fig. 1 Equivalent circuit of solar cells

Table 1 Specifications of OFFC silicon solar panels.

Current Temp. Coefficient	$\alpha = 0.002086$	[A/°C]
Voltage Temp. Coefficient	$\beta = 0.0779$	[V/°C]
Reverse Saturation Current	$I_0 = 0.5 \times 10^{-4}$	[A]
Short Circuit Cell Current	$I_{sc} = 2.926$	[A]
Cell Resistance	$R_s = 0.0277$	[Ω]
Cell Material Coefficient	$\lambda = 20.41$	[1/V]

Computed (Eq.2) and measured V-I as well as P-I characteristics for one OFFC solar panel are shown in Fig.2 for two insolation levels (e.g., 2.5A/2.9A=%86 and 1.7A/2.9A=%59 of the full insolation level).

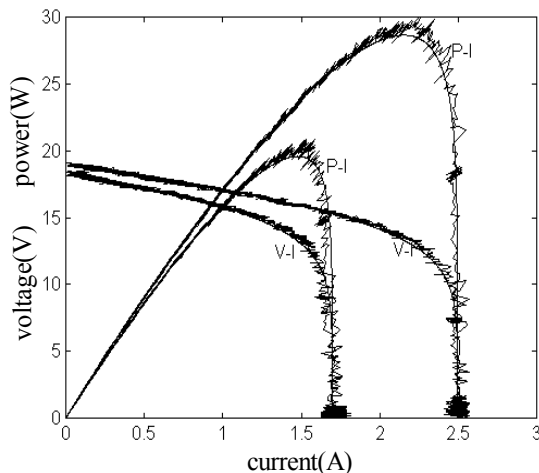

Fig. 2 Computed (full lines) and measured (noisy lines) nonlinear V-I and P-I characteristics of one OFFC silicon solar panel.

3 The fuzzy MPPT

To determine the operating point corresponding to maximum power for different insolation levels, Eq.2 is commonly used to compute the partial derivative of power with respect to cell current [6] or cell voltage [7]. Instead of finding the maximum via derivative, we use a fuzzy logic controller (FLC). Usually, a DC/DC converter is utilized between the panel and the load for the purpose of MPP tracking.

The fuzzy tracker of reference [8] is not accurate under varying temperature conditions. Figure 3 shows the P-I characteristic of solar panel at two different temperatures. Suppose the temperature is T1 and the solar panel operating point is in maximum power point as MPP1. By increasing of temperature to T2, the actual maximum power point is moved to MPP2. By considering the fuzzy rules of [8], the next operating point of solar panel is moved to A and then moved to

the left side of P-I characteristic (e.g., point B in Fig.3). In the proposed fuzzy MPPT of this paper, this problem is solved by considering the variation of converter duty cycle as the input of fuzzy controller, and therefore the operating point is moved to MPP2. The fuzzy MPPT of reference [9] behaves like the hill climbing technique and has similar disadvantages (e.g., steady-state oscillation about the solution, wrong tracking direction under rapidly changing irradiation, ...).

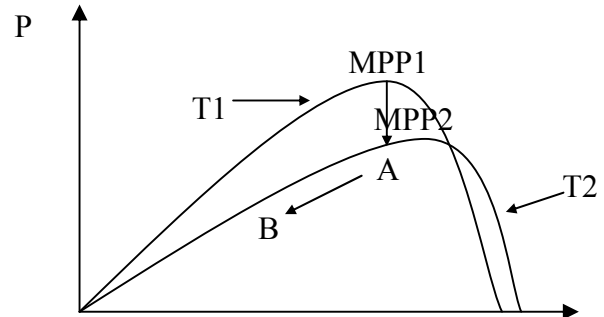

Fig. 3 P-I characteristics of a typical solar panel I_{at} at two different temperature levels ($T1 < T2$).

In this paper a new fuzzy MPPT is proposed. A functional block diagram of FLC for the proposed MPP tracker is shown in Fig.4. Inputs of the fuzzy processor (FP) include dP/dI and its variations (to improve accuracy) as well as the variations of converter duty cycle (to improve dynamic characteristics). $U(K)$ and $\Delta U(k)$ denote the outputs of the fuzzy controller and FP, respectively. Note that the output variable corresponding to FP is $\Delta U(K)$ rather than $U(K)$. This is due to the PI-like behavior of FLC that reduces the system steady state error.

Input and output variables of FLC are related by the following equations:

$$\frac{dP}{dI}(k) = \frac{p_{SA}(k) - p_{SA}(k-1)}{i_{SA}(k) - i_{SA}(k-1)} \quad (3)$$

$$\Delta \left(\frac{dP}{dI}(k) \right) = \frac{dP}{dI}(k) - \frac{dP}{dI}(k-1) \quad (4)$$

$$\Delta DC(k) = \Delta U(K-1) \quad (5)$$

$$U(k) = U(k-1) + \Delta U(k) \quad (6)$$

where $p_{SA}(k)$ and $i_{SA}(k)$ are the power and current of the solar array, respectively, and $U(K)$ is the duty cycle of buck converter.

The fuzzy processor includes three functional blocks: fuzzification, fuzzy rule algorithm, and defuzzification.

Fuzzification:

The fuzzy logic controller requires that each control input variables be expressed in fuzzy set notations using linguistic variables. These variables (characterized by membership functions) are used to decompose each system variable in the fuzzy regions. FP inputs can be measured or computed from the voltage and current of solar panel. Fig.5 shows the membership function of input and output variables in which membership functions of input variables dP/dI and $\Delta(dP/dI)$ have five fuzzy subsets and only three fuzzy subsets are

considered for ΔDC . Five fuzzy subsets are considered for the membership function of the output variable. These input variables are expressed in terms of linguistic variables (such as Z (zero), P (positive), N (negative), PB (positive big), PS (positive small), NB (negative big), NS (negative small)) using basic fuzzy subsets.

The Fuzzy Rule Algorithm:

The fuzzy rule algorithm includes 75 fuzzy control rules (five fuzzy subsets for each input variables dP/dI and $\Delta(dP/dI)$ and three fuzzy subsets for $\Delta(DC)$). These rules are implemented by a personal computer and used for the control of buck converter (tracker) such that maximum power is achieved at the output of the solar panel at all different conditions.

In the realization of the FLC, the linguistic description is expressed in terms of "IF ... THEN" labels and the following fuzzy logic inferences:

- R_1 : IF dP/dI is PS AND $\Delta(dP/dI)$ is NB AND $\Delta(DC)$ is N THEN ΔU is PS.
- R_2 : IF dP/dI is PS AND $\Delta(dP/dI)$ is NS AND $\Delta(DC)$ is P THEN ΔU is PB.

Two achieve system stability under variable temperature conditions and to overcome the limitations of [8], 16 additional fuzzy rules have been considered. For example, two of this rules as follows:

- R_1 : IF dP/dI is NB AND $\Delta(dP/dI)$ is NB AND $\Delta(DC)$ is Z THEN ΔU is PB.

- R_2 : IF dP/dI is PS AND $\Delta(dP/dI)$ is NS AND $\Delta(DC)$ is Z THEN ΔU is NS.

In the proposed MPPT, the Mamdani's fuzzy inference method is used with the Max-Min fuzzy combination operator. Fig.6 illustrates the Max-Min composition for a typical case, where $dP/dI = 0.02$, $\Delta(dP/dI) = 40$ and $\Delta(DC) = -0.01$.

Defuzzification:

The output of fuzzy controller is a fuzzy subset. As the actual system requires a nonfuzzy value of control, defuzzification is required. Several methods of defuzzification are available. Of these, the Mean of Maxima (MOM) and Center of Area (COA) methods are most commonly used. The COA method is usually selected for control applications. Therefore COA method is used for defuzzification in the proposed MPP tracker of this paper:

$$\Delta U(K) = \frac{\sum_{i=1}^n \mu(D_i) D_i}{\sum_{i=1}^n \mu(D_i)} \quad (7)$$

where D_i are the centers of Max-Min composition output membership functions and $\Delta U(k)$ is the output of the fuzzy processor.

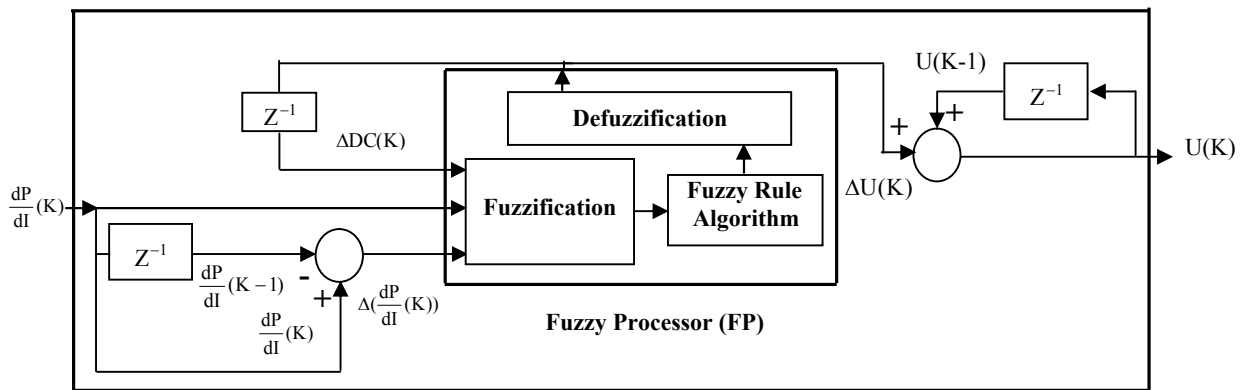

Fig. 4 Functional block diagram of the fuzzy logic controller (FLC).

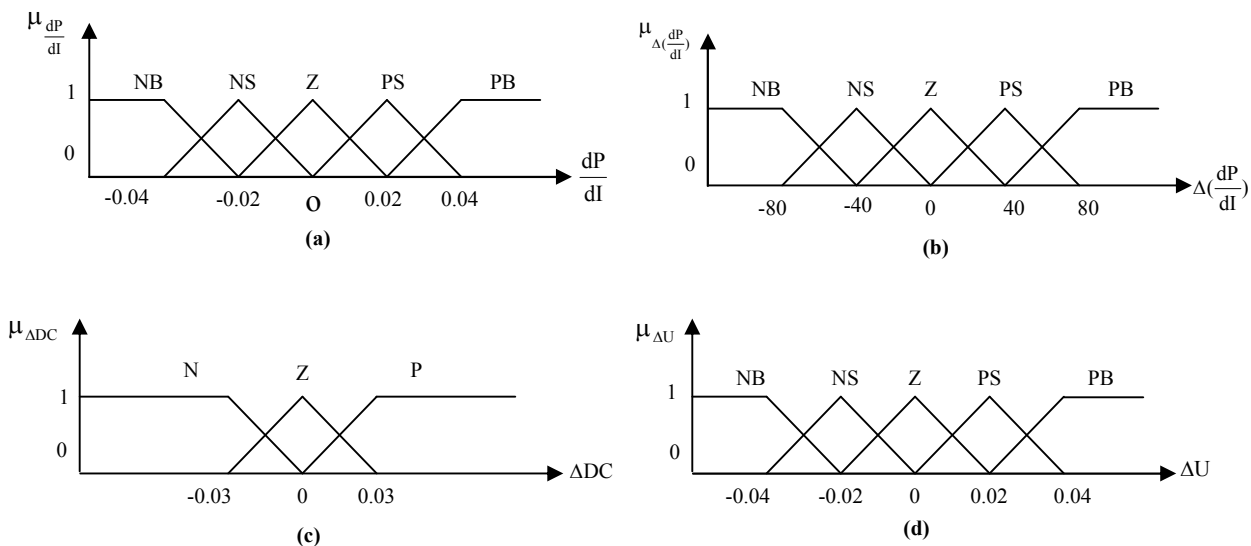

Fig. 5 Membership functions for: (a) input dP/dI , (b) input $\Delta(dP/dI)$, (c) input $\Delta(DC)$, (d) output ΔU .

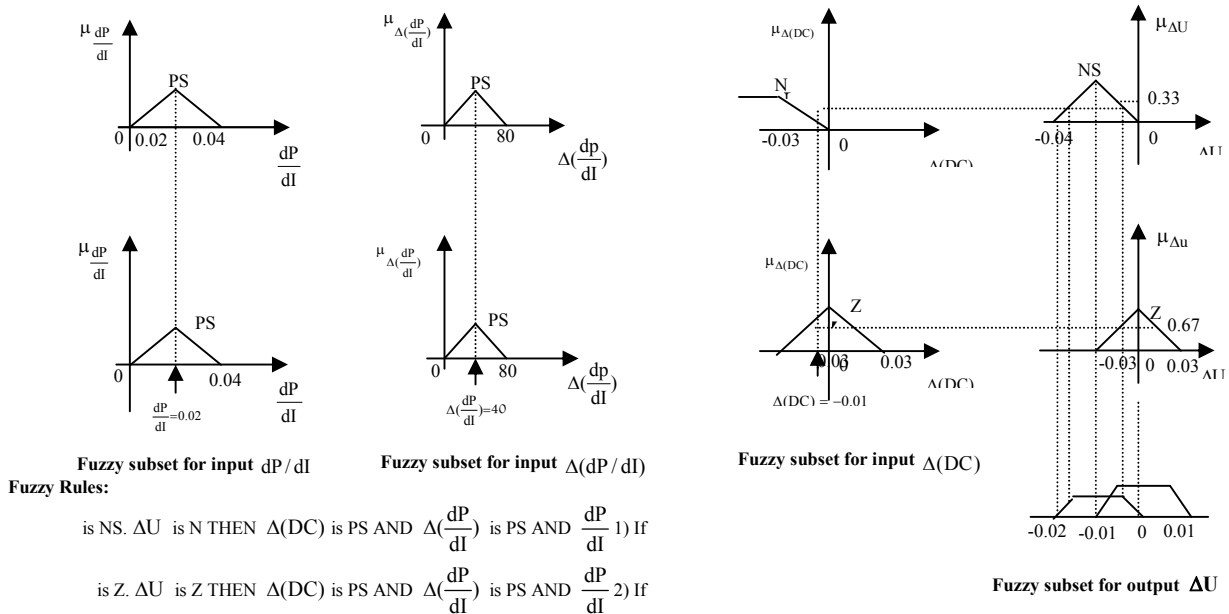

Fig. 6 Illustration of the Max-Min composition for a typical case.

4 Simulation of the fuzzy MPPT

For the simulation of fuzzy MPPT with solar panel and resistive load the Matlab/Simulink software and its facilities are used as shown in Fig.7. This system includes:

- **PV Source Block** – simulates the nonlinear V-I characteristics of one OFFC solar panel (Fig.7(b)) employing the solar panel short circuit current, I_{sc} , (is equal to I_{ph} in Eq.2) as a measure of insolation level. The “V-I characteristic” block calculates the PV voltage as a function of PV and short circuit currents (Eq.2). We have introduced a delay function to improve the convergence of solution.
- **PWM Block** – generates the pulse signals for the buck converter based on the desired duty cycle (Fig.7(c)).
- **Fuzzy Controller Block** – simulates the fuzzy MPPT process and computes the desired duty cycle of the buck converter using solar panel voltage and current (Eqs.3-7) and the fuzzy processor unit of Fig.4. The “FP” block performs the fuzzification, fuzzy rule algorithm and defuzzification processes (Fig.6(d)).
- **Buck Converter Block** – simulates the buck converter characteristics (Fig.7(e)).

5 Construction of the fuzzy MPPT

For the experimental investigation of the proposed fuzzy MPPT techniques. A microprocessor-based tracker (Fig.8) with the following capabilities was constructed and used:

- Implementing the fuzzy MPPT technique.
- Continual control of buck DC/DC converter according to the fuzzy tracking method.
- On-line measurements of solar panel voltage and current as well as computing the fuzzy processor input parameters (Fig.4).

The constructed fuzzy-based MPP tracker consists of the following parts (Figs. 8-9):

- **Silicon solar panel** - one silicon solar panel manufactured by OFFC with a maximum output power

of about 35W is used to generate solar energy.

- **Peak power tracker unit** - a buck DC/DC converter is used between silicon solar panel and load. This converter tracks the maximum power point of the solar panel based on PWM signal generated by control unit. The PWM signal is used for turn on and off of converter switching element. The IRF 540 power MOSFET is used as the switching element. Input and output current and voltage sensors are used for signal measurements and reduction of noise and harmonics.

- **Control unit** - a personal computer, A/D and D/A converters card, interface circuits and a fuzzy controller algorithm are used to record and process measured voltage and current waveforms and to compute required signals for control and drive circuits of buck converter. The ADDA-12 card is an A/D and D/A high performance data conversion card operating at a twelve-bit resolution for IBM PC and compatible systems. This card operates with one channel for twelve-bit data transfer from digital to analog and sixteen channels for twelve-bit analog to digital data conversion. The software program is in basic language. The personal computer implements the proposed fuzzy algorithm and generates the required signals for the IC op07 comparator. The fuzzy algorithm including fuzzification, defuzzification and fuzzy rules are implemented by the personal computer. The other input of IC op07 comparator is the ramped signal and is generated by function generator. The output of computer can not be used for driving the IRF 540 power MOSFET. Therefore, a driver unit is used. The generated signals by the driver unit are used as the input of the MPP tracker. Load voltage and current are continuously measured and used by the fuzzy algorithm to compute the optimal converter duty cycle. Input variables of fuzzy controller are filtered and measured by “the input and output filters & sensors sections”, as shown in Fig.8.

- **Load** - a resistive load is connected to solar panel via buck converter.

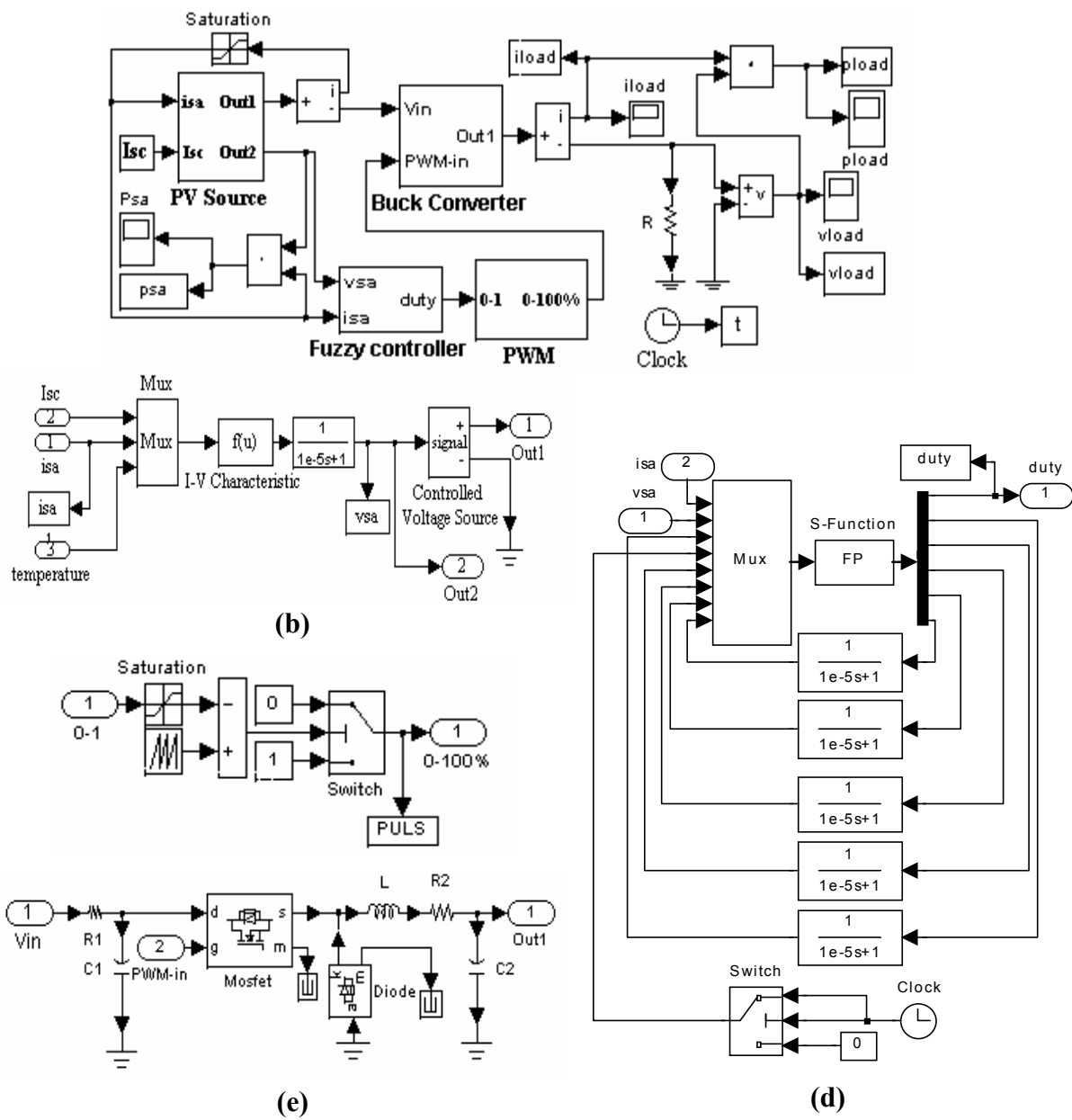

Fig. 7 Simulation of the fuzzy MPPT with resistive load ($R=1.2 \Omega$, $L=1 \text{ mH}$, $R_1 = .05 \Omega$, $C_1 = 2200 \mu\text{F}$, $R_2 = .001 \Omega$, $C_2 = 2200 \mu\text{F}$): (a) circuit diagram; (b) detail of “PV Source” block; (c) detail of “PWM” block; (d) detail of “Fuzzy Controller” block; (e) detail of “Buck Converter” block.

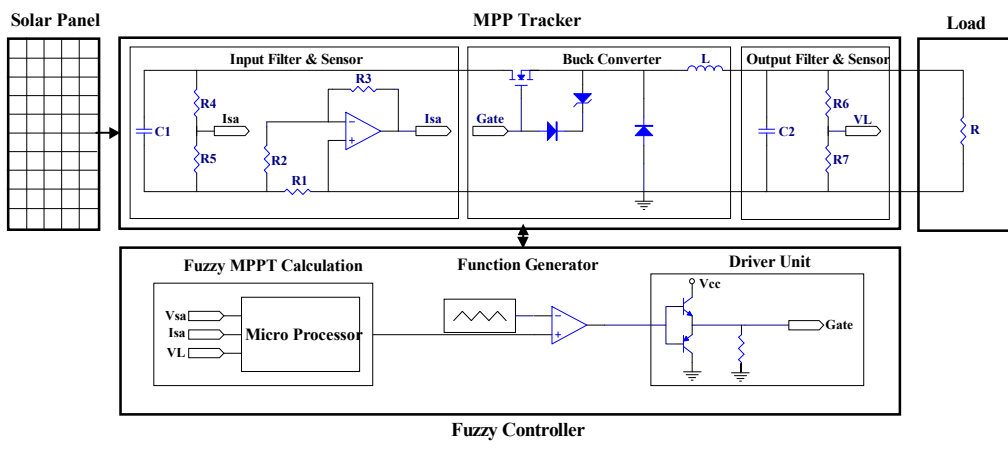

Fig. 8 Block diagram of the constructed fuzzy MPP tracker.



Fig. 9 The constructed fuzzy MPPT system.

6 Simulated and measured results

In order to investigate the performance and accuracy of the proposed fuzzy MPPT technique measured voltage, current and power waveforms (Fig.8) under different operating conditions are compared with theoretical results generated by Matlab/Simulink facilities (Fig.7). Two different cases are investigated:

Case 1 without the MPP tracker (e.g., direct connection of solar panel and the load).

Case 2 with the MPP tracker (placed between the solar panel and load).

Two different operating conditions are investigated: high insolation level (at 1:30 p.m., June 4, 2002) and low insolation level (at 9:30 a.m., June 4, 2002).

Experiments are performed using the constructed system of Fig.8.

Fig.10 shows computed and measured solar panel voltage, current and power characteristics as well as the load voltage under high insolation condition. These results indicate an increase of about 350% in PV output power in the present of the fuzzy MPP tracker.

Our extensive measurements indicate that the amount of increase in PV output power highly depends on the environmental conditions and the load level. Note that the transient responses are not measured and only their computed waveforms are shown. Fig.11 shows computed and measured results for a low insolation level (e.g., maximum solar panel power is only about 15 W). As expected, MPP tracker introduced a considerable increase of PV output power (e.g., from 4W to 15W).

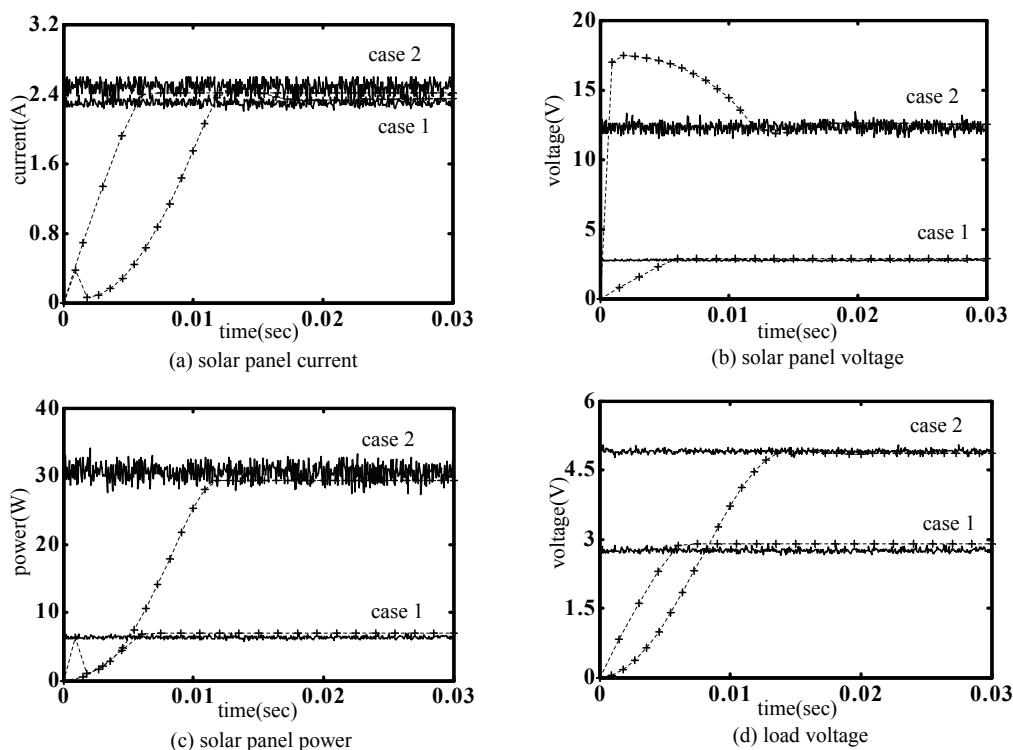

Fig. 10 Computed (dotted lines with + sign) and measured (full noisy lines) results under high insolation condition: Case 1- without the tracker (direct connection of solar panel and load), Case 2- with the fuzzy MPP tracker. Experiment date: June 4, 2002, 1:30 p.m., Tehran, Iran.

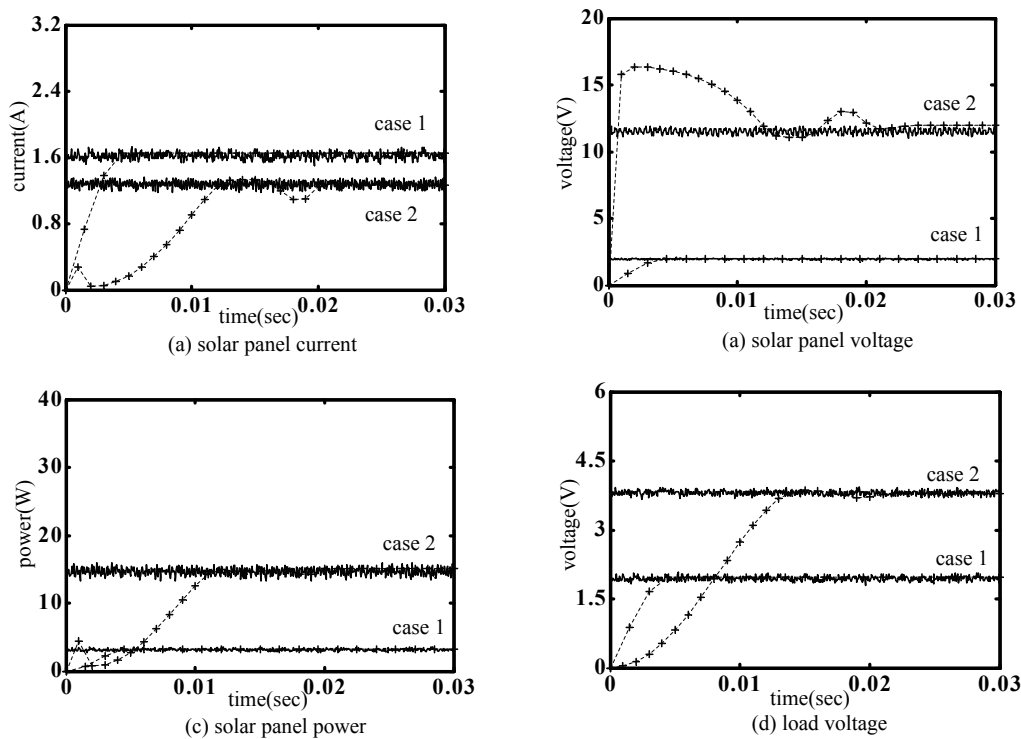

Fig. 11 Computed (dotted lines with + sign) and measured (full noisy lines) results under low insolation condition: Case 1- without the tracker (direct connection of solar panel and load), Case 2- with the fuzzy MPP tracker. Experiment date: June 4, 2002, 9:30 a.m., Tehran, Iran.

The proposed fuzzy tracker has better accuracy and dynamic response as compared with [8-9] since:

- The same traditional fuzzification and defuzzification approaches and formulas are used as in the proposed method of [8-9].
- More rule basis are used in the proposed fuzzy rule algorithm (e.g., 75 rules as compared to 25 rules used in references [8-9]). This will increase the accuracy of the proposed MPP tracker.
- More fuzzy inputs are used (e.g., three inputs as compared to two inputs used in references [8-9]). Since the variations of converter duty cycle is considered as a fuzzy input parameter, the dynamic performance is improved.

7 Conclusion

This paper presents a fuzzy-based maximum power point tracker for photovoltaic applications. Input parameters of the proposed fuzzy controller include dP/dI and its variations as well as the variation of converter duty cycle. Simulated (Fig.7) and measured (Fig.8) waveforms show good agreements for the constructed photovoltaic system with fuzzy MPP tracker and a resistive load. Some main advantages of the proposed fuzzy MPP tracker are as follows:

- The proposed fuzzy tracker is naturally robust to environmental (e.g., insolation, temperature and aging) and parameter variations.
- Considerable increase in solar output power in the presence of fuzzy MPP tracker is achieved (e.g., about 350%).
- The fuzzy tracker has high accuracy under different operating conditions.
- The proposed fuzzy tracker performs online adaptive search of solar panel maximum power.
- The proposed tracker does not require any external sensor or a dummy solar panel for

detecting temperature and solar intensity.

- The proposed fuzzy tracker has fine performance for different load types (R, L, C, RL, RC, etc.) since the performances of fuzzy controllers are not load dependent.

8 References

- [1] T. Hiyama, S. Kouzuma, T. Iimakudo, "Identification of Optimal Operating Point of PV Modules using Neural Network for Real Time Maximum Power Tracking Control", IEEE Trans. on Energy Conversion, Vol.10, No.2, June 1995.
- [2] T. Hiyama, K. Kitabayashi, "Neural Network Based Estimation of Maximum Power Generation", IEEE Trans. on Energy Conversion, Vol.10, No.3, Sept. 1997.
- [3] C. Hua, J. Lin, C. Shen, "Implementation of a DSP-Controlled Photovoltaic System with Peak Power Tracking", IEEE Trans. on Industrial Elec., Vol.45, No.1, Feb. 1998.
- [4] J.H.R. Enslin, D.B. Snyman, "Combined Low-cost, High-Efficient Inverter, Peak Power Tracker and Regulator for PV Applications", IEEE Trans. on Power Electronics, Vol.6, No.1, January 1998.
- [5] J.H.R. Enslin, M.S. Wolf, D.B. Snyman, W. Swiegrs, "Integrated Photovoltaic Maximum Power Point Tracking Converter", IEEE Trans. on Energy Conversion, Vol.44, No.6, Dec. 1997.
- [6] S.M. Alghuwainim, "Speed Control of a PV Powered DC Motor Driving a Self-Excited Three-Phase Induction Generator for Maximum Utilization Efficiency", IEEE Trans. on Energy Conversion, Vol.11, No.4, Dec. 1998.

- [7] M.A.S. Masoum, H. Dehbonei, E.F. Fuchs, "Theoretical and Experimental Analyses of Photovoltaic Systems with Voltage and Current-Based Maximum Power Point Tracking", Accepted for publication in IEEE Trans. on Energy Conversion.
- [8] C.Y. Won, D.H. Kim, S.C. Kim, W.S. Kim, H.S. Kim, "A New Maximum Power Point Tracker of Photovoltaic Arrays using Fuzzy Controller", Proceedings of the IEEE Power Elec. Specialists Conference, 1994, pp.396-403.
- [9] M.G. Simoes, N.N. Franceschetti, "Fuzzy Optimization Based Control of a Solar Array", IEE Proc. Electr. Power Appl., Vol.146, No.5, Sep.1999, pp.552-558.
- [10] M. Zahran, A. Hanafy, O. Mahgoub, M. Kamel, "FLC based photovoltaic battery diesel hybrid system management and control", 35th intersociety Energy Conversion Engineering Conference and Exhibit, IECEC 2000, Vol.2, pp.1502-1518, 2000.
- [11] W.C. So, C.K. Tse, Y.K. Lee, "A fuzzy controller for DC-DC converters", IEEE PESC, 94, Taiwan, pp.315-320, 1994.
- [12] B.R. Line, "Analysis of fuzzy control Method applied to DC-DC converter control", IEEE APEC, 98, pp.22-28, 1993.
- [13] Y. Shi, P.C. Sen, "A new defuzzication method for fuzzy control of power converters", proceedings of IEEE Industry applications Conference, Vol.2, pp.1202-1209, 2000.
- [14] M.G. Simoes, N.N. Franceschetti, M. Friedhofer, "A Fuzzy Logic Based Photovoltaic Peak Power Tracking Controller", IEEE International Symposium Industrial Electronics, Vol.1, pp.300-305, 1998.
- [15] A.M.A. Mahmoud, H.M. Mashady, S. A. Kandil, H. E. Khashab, M. N. F. Nashed, "Fuzzy Logic Implementation for Photovoltaic Maximum Power Tracking", Proc. of the 2000 IEEE International Workshop on Robot and Human Interactive Communication Osaka, Japan, pp.155-160, Sep.2000.
- [16] M.G. Simoes, N.N. Franceschetti, "Fuzzy Optimization Based Control of Solar Array System", IEE Proc. Elec. Power Appl., Vol.146, No.5, pp.552-558, Sep. 1999.
- [17] J.A. Momoh, A.R. Ofolis, "Load Management and Control of the Photovoltaic (PV) System using Fuzzy Logic", Large Engineering Systems Conference and Power Engineering 2001, LESCOPE'01, pp.184-188, 2001.
- [18] T.F. Elshatter, M.T. Elhagry, E.M.AL. Zahab, A. A. Elkousy, "Fuzzy Modeling of Photovoltaic Panel Equivalent Circuit", Twenty Conference Record of the Photovoltaic Specialists Conference, IEEE 2000, pp.1656-1659, 2000.
- [19] M. Ciscione, G. Giustolisi, A. Lionetto, M. Muscara, G. Palumbo, "A Fuzzy Controller for Step-Up DC/DC Converters", 8th IEEE International Conference on Electronics Circuits and Systems, ICECS 2001, Vol.2, pp.977-980, 2001.
- [20] K.H. Hussein, I. Muta, "Maximum Photovoltaic Power Tracking: An Algorithm for Rapidly Changing Atmospheric Conditions", IEE Proceedings on Generation, Transmission, and Distribution, Vol.142, No.1, pp.59-64, Jan. 1995