

Investigation of Two Vector Control Based Methods for Static Synchronous Series Compensator

A. Kazemi*, A. Badri* and S. Jadid*

Abstract: In this paper, two vector control systems for investigating the performance of Static Synchronous Series Compensators (SSSC) in steady state conditions are presented that are based on famous d-q axis theory. The workability of proposed method to simplify the SSSC mathematical expressions is shown. The performance of SSSC with two different vector controllers, first based on d-q line currents(indirect control) and the second a heuristic vector control based on real and reactive line powers (direct control), are investigated through simulation. It is found that the new introduced direct control produces better performance in controlling AC power system. Finally the simulation results of an elementary two-machine system with SSSC in different cases are investigated.

Keywords: AC transmission line, Vector control, SSSC, Real and reactive power.

1 Introduction

Electric power flow through an alternating transmission line is a function of the line impedance, the magnitudes of the sending-end and receiving-end voltages, and the phase angle between these voltages. The power flow can be decreased by inserting an additional inductive reactance in series with the transmission line, thereby increasing the effective reactance of transmission line between two ends. Also, the power flow can be increased by inserting an additional capacitive reactance in series with transmission line, thereby decreasing the effective reactance of transmission line between two ends.

Traditionally, in order to control the power flow of the transmission line, the effective line reactance is controlled by using fixed or thyristor-controlled series capacitors or inductors. Recently a new power flow controllers entitled Flexible Alternating Current Transmission Systems (FACTS) which use solid-state switching converters have been proposed.

The Static Synchronous Series Compensator (SSSC) is among FACTS devices that is connected in series with line and controls the effective impedance of the line by injecting an almost sinusoidal voltage of variable magnitude in series with transmission line. With no external DC link most of injected voltage which is in

quadrature with the line current emulates an inductive or capacitive reactance in series with the transmission line that influences the electric reactive power flow. A small part of injected voltage which is in phase with the line current provides the losses in the inverter. In fact SSSC injects an alternating voltage proportional to the line current. When SSSC injects a voltage leading the line current, it emulates an inductive reactance in series with transmission line, causing the power flow as well as the line current to decrease and operates as an inductor. When SSSC injects a voltage lagging the line current, it emulates a capacitive reactance in series with transmission line, causing the power flow as well as the line current to increase and operates as a capacitor. The SSSC equipped with a source of energy in the DC link can supply or absorb both the real and reactive powers to or from the line, without generation resonance and oscillation in transmission line.

Many studies have been implemented in order to investigate the operation of SSSC in steady state and dynamic conditions. Ref [1] uses EMTP to describe the fundamental and implement the operation of SSSC using a 24-pulse harmonic neutralized voltage source as SSSC inverter. Singh and Chandra proposed two sliding-mode and fuzzy controllers to examine the dynamic response of SSSC [2]. A current controlled VSI inverter has been used for SSSC to inject series voltage. Furthermore a closed-loop control scheme for the system is described that contains VSI inverter and a PWM current controller.

In Ref [3] Transient Network Analyzer (TNA) has been implemented to simulate SSSC with GTO based voltage source inverter to provide series compensation for SSSC. Capability of active and reactive control of SSSC

Iranian Journal of Electrical & Electronic Engineering, 2005.
Paper first received 11th January 2005 and in revised form 15th July 2006.

* The authors are with the Center of Excellence for Power System Automation and Operation, Department of Electrical Engineering, Iran University of Science and Technology, Narmak, Tehran, 16846-13114, Iran.

E-mail: kazemi@iust.ac.ir, a_badri@ee.iust.ac.ir, jadid@iust.ac.ir.

has been presented through simulation. Han and et.al presented a SSSC based on a multi-bridge inverter that consists of six H-bridge modules per phase [4]. EMTP has been used to investigate dynamic simulation of SSSC in order to inject series voltage and compensation.

Referring to some existing studies about the performance of SSSC for line compensation, it is observed that most of them use some complicated models in order to simulate the SSSC inverter and therefore obtain SSSC series injected voltage [1-4]. In this paper in order to avoid using such formulas the vector control theory is introduced and its application to simplify the studies of SSSC performance is presented.

At first the concept of vector control to reduce the size of the model is introduced. Then the application of vector control for SSSC based on d-q axis theory is discussed and then it will be developed for indirect and direct categories. A PI controller is employed to simulate the SSSC through indirect and direct control schemes.

Finally in simulation results the dynamic performance of SSSC on an elementary two machine system is presented and its impacts on transmission lines and voltage are investigated.

2 Theory

In this section we deal with the mathematical analysis and modeling of a vector controlled SSSC.

The use of vectors simplifies the analysis and control of a SSSC connected to a symmetrical three-phase AC network.

Vector control has long been used in electrical machine analysis and is now being applied more widely to electrical power system analysis and control. In this analysis instantaneous three-phase variables are converted to vectors with orthogonal d-q axis components in a synchronous rotating d-q axis system and therefore reduce the order of system and simplify the complicated calculations.

A Simple power transmission system with a SSSC is illustrated in Fig 1.

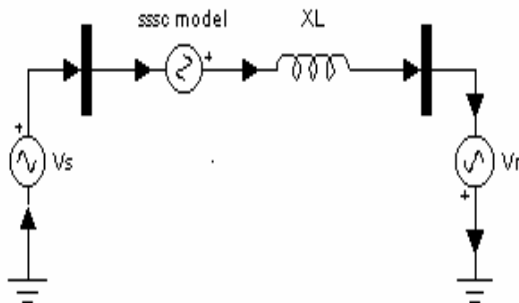

Fig. 1 A Simple Power System with SSSC

The SSSC is modeled with a voltage source that injects variable voltage to power system in both inductive and capacitive compensation modes.

Referring to Fig. 1 the SSSC input circuit equations can be written in per-unit as:

$$\frac{d}{dt} \begin{bmatrix} i_a \\ i_b \\ i_c \end{bmatrix} = \begin{bmatrix} -\frac{r}{L} & 0 & 0 \\ 0 & -\frac{r}{L} & 0 \\ 0 & 0 & -\frac{r}{L} \end{bmatrix} \begin{bmatrix} i_a \\ i_b \\ i_c \end{bmatrix} + \begin{bmatrix} \frac{1}{L}(v_{sa} + v_{ca} - v_{ra}) \\ \frac{1}{L}(v_{sb} + v_{cb} - v_{rb}) \\ \frac{1}{L}(v_{sc} + v_{cc} - v_{rc}) \end{bmatrix} \quad (1)$$

Consider the vertical transformation of variables from three-phase quantities to the synchronously rotating d-q plane defined by following equations, in which the reference vector and therefore the d-axis (d_s) and q-axis (q_s) are defined by synchronous reference frame and d_s is conformed with a-axis in three-phase frame. (Fig 2).

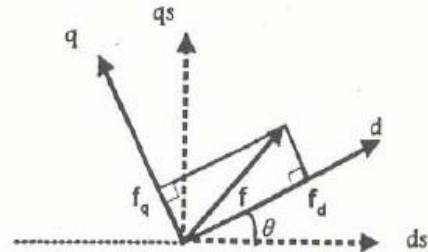

Fig. 2 Vector diagram of d-q plane

$$[T] \begin{bmatrix} i_a \\ i_b \\ i_c \end{bmatrix} = \begin{bmatrix} i_d \\ i_q \end{bmatrix} \quad \text{and} \quad [T] \begin{bmatrix} v_{sa} \\ v_{sb} \\ v_{sc} \end{bmatrix} = \begin{bmatrix} v_{sd} \\ v_{sq} \end{bmatrix} \quad (2)$$

Where:

$$[T] = \frac{2}{3} \begin{bmatrix} \cos \theta & \cos(\theta - \frac{2\pi}{3}) & \cos(\theta + \frac{2\pi}{3}) \\ -\sin \theta & -\sin(\theta - \frac{2\pi}{3}) & -\sin(\theta + \frac{2\pi}{3}) \\ \frac{1}{\sqrt{2}} & \frac{1}{\sqrt{2}} & \frac{1}{\sqrt{2}} \end{bmatrix} \quad (3)$$

And

$$\theta = \tan^{-1} \left(\frac{i_{qs}}{i_{ds}} \right) \quad (4)$$

And in static reference frame:

$$\begin{bmatrix} i_{ds} \\ i_{qs} \\ 0 \end{bmatrix} = \frac{2}{3} \begin{bmatrix} 1 & -\frac{1}{2} & -\frac{1}{2} \\ 0 & \frac{\sqrt{3}}{2} & -\frac{\sqrt{3}}{2} \\ \frac{1}{\sqrt{2}} & \frac{1}{\sqrt{2}} & \frac{1}{\sqrt{2}} \end{bmatrix} \begin{bmatrix} i_a \\ i_b \\ i_c \end{bmatrix} \quad (5)$$

In the synchronously reference frame Eq.1 can be written as:

$$\frac{d}{dt} \left[(i_d + j i_q) e^{j\omega t} \right] = \frac{-r}{L} (i_d + j i_q) e^{j\omega t} + \frac{1}{L} ((v_{sd} + v_{cd} - v_{rd}) + j(v_{sq} + v_{cq} - v_{rq})) e^{j\omega t} \quad (6)$$

Where:

$$\omega = d\theta/dt \quad (7)$$

From Eq.6

$$\frac{di_d}{dt} = \omega i_q - \frac{r}{L} i_d + \frac{1}{L} (v_{sd} + v_{cd} - v_{rd}) \quad (8)$$

$$\frac{di_q}{dt} = -\omega i_d - \frac{r}{L} i_q + \frac{1}{L} (v_{sq} + v_{cq} - v_{rq}) \quad (9)$$

Eq. 8 and 9 are mathematical models of a SSSC in synchronously rotating d-q reference frame that is used in the following indirect controller for SSSC.

3 Control of SSSC System

In this section two different control systems for controlling real and reactive powers of AC transmission line by SSSC are investigated. These two controllers are vector controllers based on d-q axis line current (indirect controller) and a heuristic controller base on real and reactive powers (direct controller), respectively. It can be seen that performance of direct controller is better than indirect one.

3.1 Indirect control scheme for SSSC

From the instantaneous power theory derived by Akagi [6] the instantaneous real and reactive powers at the receiving-end are given by Eqs. 10 and 11.

$$P = \frac{3}{2} (v_{rd} \cdot i_d + v_{rq} \cdot i_q) \quad (10)$$

$$Q = \frac{3}{2} (v_{rd} \cdot i_q - v_{rq} \cdot i_d) \quad (11)$$

In transmission system the described values of real and reactive power would usually be specified by the coordinating system controller. Therefore reference values for the desired real and reactive power flows are used as the inputs to the SSSC control system. By rearranging Eqs. 10 and 11, using the real and reactive power references P_{ref} and Q_{ref} , the reference line d-q axis currents are:

$$i_{dref} = \frac{2}{3} \frac{(P_{ref} \cdot V_{rd} - Q_{ref} \cdot V_{rq})}{V_{rd}^2 + V_{rq}^2} \quad (12)$$

$$i_{qref} = \frac{2}{3} \frac{(P_{ref} \cdot V_{rq} + Q_{ref} \cdot V_{rd})}{V_{rd}^2 + V_{rq}^2} \quad (13)$$

Using above equations and Eqs. 8 and 9, the block diagram of indirect controller of SSSC for controlling real and reactive powers of transmission line using vector control, is shown in Fig 3.

The measured currents i_d and i_q are feedback and compared to the reference currents to produce error signals. These error signals are used by the PI controllers to regulate v_{cd} and v_{cq} respectively.

According to Eqs. 8 and 9 for $\omega L \gg r$ in steady state condition, the direct-gain from v_{cd} to i_q (or v_{cq} to i_d) is much bigger than v_{cd} to i_d (or v_{cq} to i_q) [5]. In other words in above real conditions, i_d is related to v_{cq} and i_q is related to v_{cd} [2]. In order to compensate for small direct-gains, the controller must have a large gain so that the inverter can be controlled quickly. Since there is some coupling between d and q current loops (due to $\omega i_q, \omega i_d$, in Eqs 8, 9) there will be an almost big interactions between the two output real and reactive power flows (Fig. 5(b)).

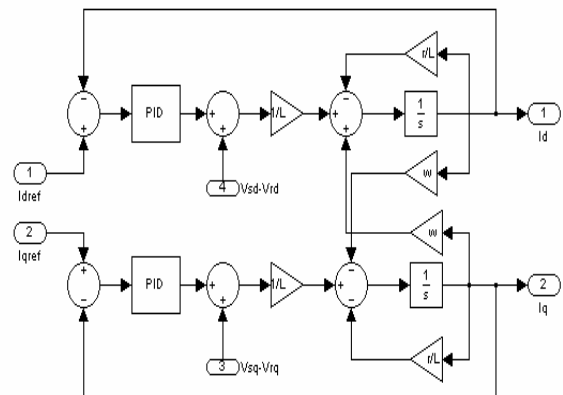

Fig. 3 Block diagram of indirect control

3.2 Direct control scheme for SSSC

As shown, in indirect control there is an interaction between real and reactive power flows. The strategy of using real and reactive powers as direct feedback signals in SSSC, to control power flows in transmission line has been discussed using different controllers [2]. In this paper in order to reduce the interaction between real and reactive powers, a heuristic control strategy using vector control and based on direct real and reactive powers as feedback control signals has been presented by the authors.

Considering Fig. 1, the line current in d-q axis model is:

$$I = \frac{(v_{sd} + jv_{sq}) + (v_{cd} + jv_{cq}) - (v_{rd} + jv_{rq})}{jX} \quad (14)$$

Considering sending-end voltage in d-q axis model ($v_{sd} + jv_{sq}$) and above current, real and reactive powers in d-q system can be derived.

$$P = \frac{1}{X} [V_{sd}(V_{sq} + V_{cq} - V_{rq}) - V_{sq}(V_{sd} + V_{cd} - V_{rd})] \quad (15)$$

$$Q = \frac{1}{X} [V_{sq}(V_{sq} + V_{cq} - V_{rq}) + V_{sd}(V_{sd} + V_{cd} - V_{rd})] \quad (16)$$

Where:

$$X = r + j\omega L$$

Assuming the practical situation that $\omega L \gg r$, in steady state condition, i_d is proportional to v_{cq} and i_q is proportional to v_{cd} [5] and therefore from Eqs. 15 and 16, real and reactive powers are proportional to v_{cq} and v_{cd} respectively, but in fact referring to Eqs. 15 and 16 due to common terms in above equations there will be interactions in AC transmission line, real and reactive powers, compensated by SSSC (Fig. 5(a))

The block diagram of direct controller system for SSSC, using vector control is shown in Fig. 4. The measured real and reactive powers are calculated and directly compared to the reference values to produce error signals. These error signals are used by the PI controllers to regulate v_{cq} and v_{cd} , respectively.

Using d-q axis voltages and rotating frame angle, the series injected voltage by SSSC can be achieved.

As shown, traditional PI controller is used in these indirect and direct vector control block diagrams. It is possible to obtain a good dynamic response of SSSC with fine tuned PI controllers. However for more complicated systems improved controllers such as robust and adaptive controllers can be used.

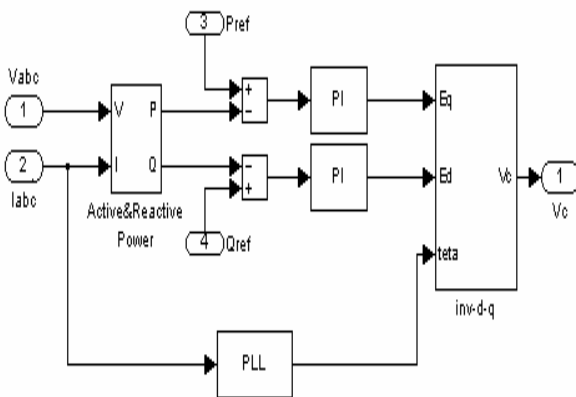

Fig. 4 Block diagram of direct control

It is clear that in direct control block diagram there is no interaction between real and reactive power loops and so this controller shows better performance.

4 Simulation Results

Computer simulation of a vector-controlled SSSC was carried out. The MATLAB SIMULINK was employed for the computer simulation. Referring to Fig. 1, the simulation parameters are listed in Table 1.

Figures 5(a) and 5(b) show the response of the SSSC for the change in reference of real power at $t=0.5$ sec and reactive power at $t=1.5$ sec in two direct and indirect vector control schemes, respectively. It is apparent that Fig. 5 (b) shows more interaction between real and reactive powers.

Table 1 Power system parameters

V_s	V_r	r	L
220 V	220 V	0.8Ω	10 mH

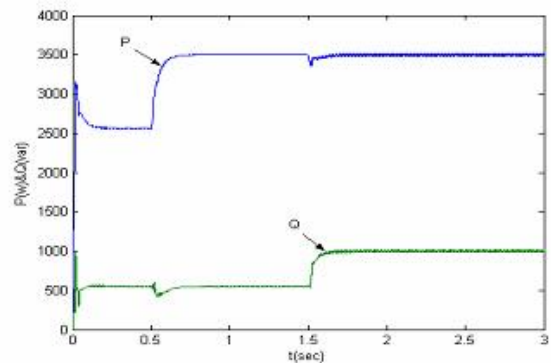

Fig. 5(a) Direct control response to step changes

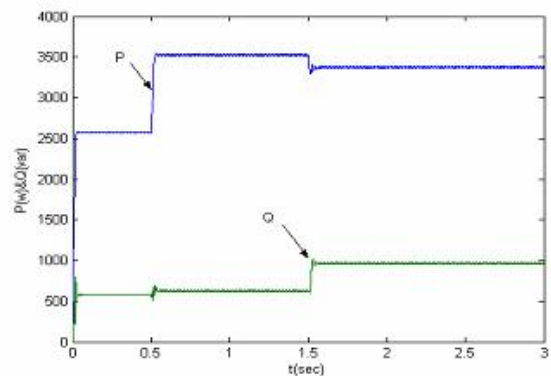

Fig. 5(b) Indirect control response to step changes

Fig. 6 shows SSSC injected voltage and Transmission line current changes during above real and reactive power variations at $t=0.05$ and 0.15 sec, respectively. It is observed that line current changes proportional to real and reactive power variations and also change in real power results severe variation in line current with respect to reactive power.

In either cases increasing active or reactive powers the SSSC injected voltage is increased. Phase angles of injected voltages are varied in such a manner that in the case of increasing active power it remains in quadrature with line current. However in case of increasing reactive power it tends to remain in phase with line current.

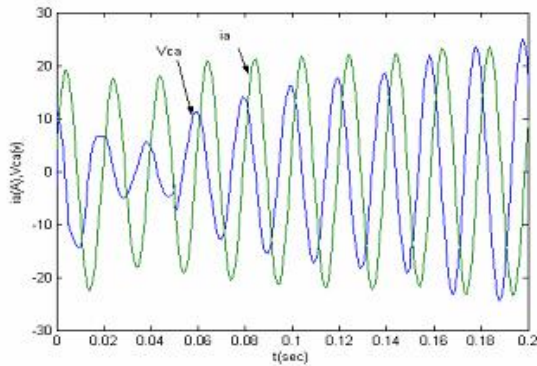

Fig. 6 Effect of real and reactive power changes on injected voltage and line current

Figures 7 and 8 show the variation of injected voltage and line current during the following changes in only real power, respectively.

- A) Increasing from 2562 to 3500w at $t=0.05$ sec
 B) Decreasing from 2562 to 1500w at $t=0.05$ sec

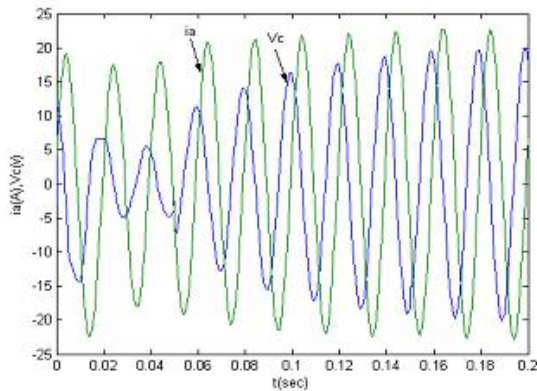

Fig. 7 Effect of increasing real power on injected voltage and line current

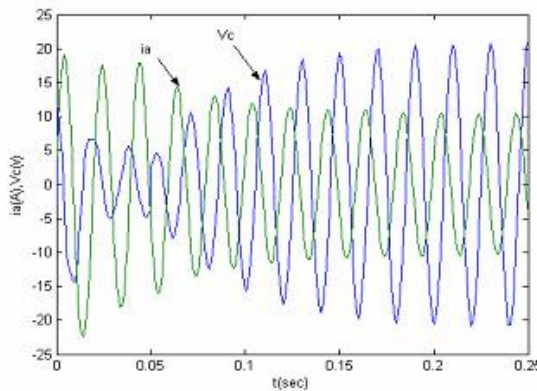

Fig. 8 Effect of decreasing real power on injected voltage and line current

Similarly Figures 9 and 10 show the variation of injected voltage and line current during following changes in only reactive power, respectively.

- A) Increasing from 900 to 1600 var at $t=0.15$ sec
 B) Decreasing from 900 to 200 var at $t=0.15$ sec

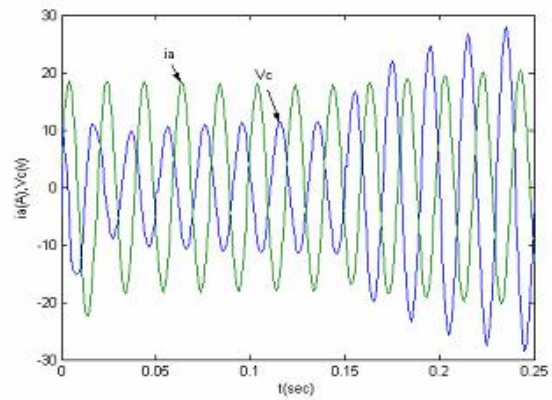

Fig. 9 Effect of increasing reactive power on injected voltage and line current

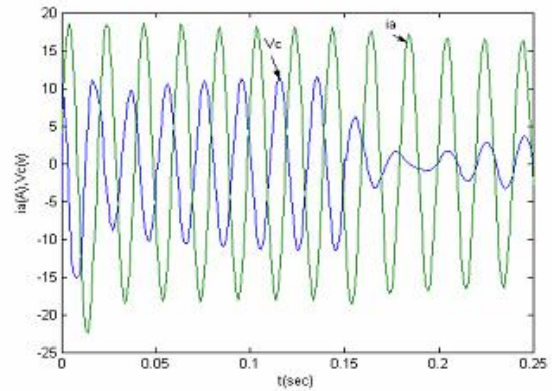

Fig. 10 Effect of decreasing reactive power on injected voltage and line current

It is observed from Figures 7 and 8 that for only changes in real power, the injected voltage remains always in quadrature with line current. In this case it is also observed that magnitude of the line current is affected proportional to real power variations [2]. Also it appears that in increasing and decreasing of real power the phase angle of SSSC injected voltage varies 180 degree.

It is further observed from Figures 9 and 10 that for only changes in reactive power, the injected voltage remains in phase with line current [2]. In this case, the magnitude of line current is not so affected (in comparison to real power variations, but varies proportional to reactive power changes as shown in Figures 9 and 10) but phase of the line current with respect to the sending-end voltage (and also injective voltage) is so affected that in C mode it injects a voltage lagging the line current (Fig.9) and in L mode injects a voltage leading the line current (Fig.10) [1-4]. Similarly it is clear that in two increasing and decreasing in reactive power modes the phase angle of SSSC injected voltage varies 180 degree.

5 Conclusion

The workability of the vector control for controlling AC transmission line power flows by SSSC was presented. The indirect and direct controllers were presented based

on transmission line currents and active and reactive powers, respectively and the capability of the latter one in order to decrease compensation interaction, was studied. For each controller the performances of SSSC in two cases, active and reactive power compensation modes were presented. Application of SSSC in inductive and capacitive compensation modes was simulated and variations of other line characteristics as well as SSSC series injected voltage were investigated.

References

- [1] K. K. Sen, "SSSC- Static Synchronous Series compensatory: Theory, Modeling, and Applications," *IEEE Trans. Power Del.*, Vol. 13, pp. 241-246, 1998.
- [2] B. N. Singh and A. Chandra, "Performance of Sliding-Mode and Fuzzy Controllers for a Static Synchronous Series compensator," *IEE Proc. Gen. Trans. Dist.*, Vol. 146, pp. 200-206, 1999.
- [3] L. Gyugyi and C. D. Scjhauder, "Static Synchronous Series compensator, A Solid – State Approach to the Series compensation for Transmission Lines," *IEEE Trans. Power Del.*, Vol. 12, pp. 406-417, 1997.
- [4] B. Han, S. Beak and G. Karady, "Dynamic Characteristics Analysis of SSSC Based on Multi-bridge Inverter," *IEEE Trans. Power Del.*, Vol. 17, pp. 623-629, 2002.
- [5] Q. Yu, S. D. Round, L. E. Norum and T. M. Undeland, "Dynamic control of a Unified Power Controller," *Power Electronics Specialists Conference (PESC)*, pp. 508-514, 1996.
- [6] H. Akagi, Y. Kanazawa and A. Nadae, "Instantaneous Reactive Power Compensators Comprising Switching Devices Without Energy Storage Components," *IEEE Trans. Industrial App.*, IA-20, pp. 625-631, 1984.