

Considering Pilot Protection in the Optimal Coordination of Distance and Directional Overcurrent Relays

Y. Damchi*, J. Sadeh^{*(C.A.)} and H. Rajabi Mashhadi*

Abstract: The aim of the relay coordination is that protection systems detect and isolate the faulted part as fast and selective as possible. On the other hand, in order to reduce the fault clearing time, distance protection relays are usually equipped with pilot protection schemes. Such schemes can be considered in the Distance and Directional Over-Current Relays (D&DOCRs) coordination to achieve faster protection systems, while the selectivity is maintained. Therefore, in this paper, a new formulation is presented for the relay coordination problem considering pilot protection. In the proposed formulation, the selectivity constraints for the primary distance and backup overcurrent relays are defined based on the fault at the end of the transmission lines, rather than those at the end of the first zone of the primary distance relay. To solve this nonlinear optimization problem, a combination of Genetic Algorithm (GA) and Linear Programming (LP) is used as a Hybrid Genetic Algorithm (HGA). The proposed approach is tested on an 8-bus, the IEEE 14-bus and the IEEE 39-bus test systems. Simulation results indicate that considering the pilot protection in the D&DOCRS coordination, not only obtains feasible and effective solutions for the relay settings, but also reduces the overall operating time of the protection system.

Keywords: Directional Overcurrent Relay, Distance Relay, Pilot Protection, Relay Coordination.

1 Introduction

Fast fault clearing is important for power systems stability and reducing the risk of equipment damages. Pilot protection schemes, which are available in modern distance relays [1], provide high speed trip for fault clearing within 100% of the protected transmission lines. In order to achieve this goal, communication channels are used in the pilot protection to send information from the local relays terminals to the remote relays terminals [2].

Transmission lines have a vital role in transferring electrical energy from bulk generating plants to distribution systems [3]. The lines can be protected by different types of protections. Distance and directional overcurrent relays have a vital role in fault clearing in transmission and sub-transmission systems. Distance relays are used as the primary or backup protections in these systems, while Directional Over-Current Relays (DOCRs) are usually employed as the backup

protections in transmission systems and as the primary or backup protections in subtransmission systems. To achieve a fast and selective protection, these two types of relays should be properly coordinated.

If distance relays are used for the protection of transmission lines, by including 80% of the lines length in the first zones of the relays, 60% of internal faults will be cleared instantaneously. On the other hand, the remaining 20% of the internal faults in both ends of the lines are cleared by the second zones of the distance relays in the remote buses, with the time delay typically around 0.3–0.6 seconds. However, high speed fault clearing is provided for all internal faults when the pilot protection is used in the transmission lines. In this situation, only a very small delay is required for the fault clearing due to the time of transferring the trip signal between the terminals. This delay will almost never exceed one or two cycles and even may be close to zero in some pilot schemes and communication paths. This is the main benefit of the pilot protection [2], and can be used in the coordination of combined distance and DOCR relays in order to reduce the overall operating time of these relays.

Up to now, several methods have been proposed for the D&DOCRs coordination. For distance and overcurrent relays coordination, a set of parameters

Iranian Journal of Electrical & Electronic Engineering, 2015.

Paper first received 29 Nov. 2014 and in revised form 18 Jan 2015.

* The Authors are with the Department of Electrical Engineering, Faculty of Engineering, Ferdowsi University of Mashhad, Mashhad, Iran.

E-mails: damchi.yaser@stu-mail.um.ac.ir, sadeh@um.ac.ir and h_mashhadi@um.ac.ir.

including operating times of the second zones of the distance relays (T_{Z2S}), pickup current settings (I_{setS}) and time multiplier settings ($TMSs$) of the DOCRs should usually be determined. In [4], the D&DOCRs coordination problem has been formulated and three protection schemes, including independent coordination of inverse time DOCR and distance relays, simultaneous coordination of these two types of relays, and the same scheme on the second one but considering the definite time DOCRs have been evaluated. In the first and the second schemes, the LP method has been used to determine the optimal $TMSs$ for all DOCRs considering specific values for the I_{setS} . Moreover, in the second scheme, the T_{Z2S} of all distance relays have been set to specific values. In [5], a new formulation has been presented to consider the effect of distance and circuit breaker failure relays on the optimal settings of the DOCRs. Moreover, the LP method has been used to determine the optimal $TMSs$ while specific values are considered for the I_{setS} , T_{Z2S} , and the operating times of the breaker failure relays. In [6], an evolutionary algorithm has been proposed for solving the D&DOCRs coordination problem and the operating times of the second and the third zones of the distance relays, $TMSs$, and I_{setS} have been considered as the optimization variables. In [7], the D&DOCRs coordination problem has been solved using the LP method with the T_{Z2S} as the optimization variable, in addition to the $TMSs$. In this study, the optimal settings for both phase and ground distance relays have been determined by considering the same values for all the operating times of the second zones of the distance relays. In [8], three LP methods, including dual simplex, path following method, and homogeneous self dual have been applied to calculate the optimal values of the T_{Z2S} and $TMSs$ for the D&DOCRs, while the I_{setS} have been assumed to be predetermined. The D&DOCRs coordination problem has been solved considering two cases including the same time settings and independent time settings for the T_{Z2S} . Based on the presented results in [8], it can be seen that the $TMSs$ of the overcurrent relays are reduced in case of the independent time settings for the T_{Z2S} . In [9], a new approach has been presented to determine the optimal settings of the D&DOCRs. In this method, the operating characteristics of the backup DOCRs are changed in such a way that the T_{Z2S} are bounded in a typical range, while the relay coordination constraints are satisfied. This change has been performed based on the fault location and the fault current. Then, the optimal $TMSs$ have been determined while specific values are considered for the T_{Z2S} and I_{setS} . In [10–13], genetic algorithm has been applied to solve the D&DOCRs coordination problem by introducing a new objective function for this problem. In [10–12], the optimal $TMSs$ are determined while the I_{setS} and T_{Z2S} are assumed to be known. In [10] and [13], using GA to select the best characteristic among standard operation characteristics has been considered as a new idea.

Furthermore, in [13], the T_{Z2} for each distance relay has been considered as an unknown variable, while the I_{set} for each overcurrent relay has been assumed as a predetermined parameter. In [14] and [15], different T_{Z2S} have been considered for the distance relays. In [14], the LP method and hybrid GA have been used to obtain the optimal settings of the D&DOCRs, whereas in [15] the coordination problem has been solved by the LP method and a hybrid particle swarm optimization (PSO). According to these studies, more appropriate optimal settings have been obtained when the hybrid GA and the hybrid PSO algorithms are used, compared to the merely LP method. In [16], the optimal I_{setS} and $TMSs$ of the DOCRs have been calculated using GA and hybrid PSO by assuming specific values for the T_{Z2S} . Based on the presented results in [16], it can be concluded that a better solution is obtained by the hybrid PSO in comparison with the GA. In [17], the D&DOCRs coordination problem has been formulated in a power network with series compensated transmission lines. Furthermore, this problem has been solved using a modified adaptive PSO. In [18], multiple embedded crossover PSO has been used to determine the optimal settings of the D&DOCRs by considering the discrimination time between the operating time of the backup DOCR and the T_{Z2} of the primary distance relay in the objective function.

Based on the literature survey conducted in this paper, up to now, the effect of the pilot protection on the calculation of the optimal settings of the distance and overcurrent relays has not been considered in the combined coordination of these two types of relays. As mentioned earlier, the pilot protection provides high speed fault clearing for the entire length of the transmission lines. This benefit can be utilized in the relay coordination procedure to achieve more appropriate optimal settings for the D&DOCRs. Hence, based on the presented discussions, in this paper a new formulation is proposed for the simultaneous coordination of the distance and overcurrent relays, considering the pilot protection. The coordination problem is solved using a hybrid genetic algorithm by assuming different time-current characteristics for the DOCRs. The obtained results show the average of T_{Z2S} and the sum of operating times of the DOCRs are reduced by including the effect of the pilot protection into the D&DOCRs coordination.

2 Proposed Method for D&DOCRS Coordination

The aim of the D&DOCRs coordination problem is to determine the settings of the distance and overcurrent relays such that the overall operating time of the primary relays is minimized, while the relay coordination constraints are satisfied. In this section, first, the D&DOCRs coordination problem is generally defined. Then, this problem is modified by considering the pilot protection.

2.1 General Formulation of the D&DOCRS Coordination Problem

In order to determine the optimal settings of the relays, an objective function should be defined. In this paper, the following objective function is considered for the coordination problem:

$$J = \sum_{i=1}^n t_i + \sum_{j=1}^m T_{Z2j} \quad (1)$$

where m and n are the numbers of the distance and directional overcurrent relays, respectively. Furthermore, t_i and T_{Z2j} represent the operating time of the i^{th} overcurrent relay for the near-end fault, and the operating time of the second zone of the j^{th} distance relay, respectively.

According to the IEEE or IEC standards, different functions are defined as the time-current characteristics of the DOCRs. Generally, these characteristics are defined as follows:

$$t_i = \frac{K \times \text{TMS}_i}{\left(\frac{I_{\text{fault}_i}}{I_{\text{set}_i}}\right)^\alpha} + \beta \times \text{TMS}_i \quad (2)$$

where K , α and β are constant values selected based on the time-current characteristics of the DOCRs and I_{fault_i} indicates the fault current passing through the i^{th} relay.

There are two groups of constraints for the D&DOCRS coordination problem, related to the selectivity of the protection system and the limits of the relay settings, which are explained as follows.

2.1.1 Selectivity Constraints

A protection system is selective if, for every primary/backup pair of relays, the operating time of the backup relay is greater than the primary relay for the faults clearing. Based on Fig. 1, this constraint for DOCRs can be expressed mathematically as:

$$\begin{aligned} t_b^{F_1} - t_p^{F_1} &\geq CTI \\ t_b^{F_2} - t_p^{F_2} &\geq CTI \end{aligned} \quad (3)$$

where $t_p^{F_1}$ and $t_b^{F_1}$ are the operating times of the primary and the backup overcurrent relays for the near-end fault, respectively, while $t_p^{F_2}$ and $t_b^{F_2}$ denote the same parameters for the far-end fault, respectively. CTI is the coordination time interval that depends on the circuit breaker operating time, relay over-travel, relay tolerance, setting errors, and the safety margin, and is typically selected in the range of 0.2–0.5 seconds.

According to Fig. 2, the selectivity constraints for D&DOCRs are defined using (4) for the faults occurring at the end of the second zone of the backup distance relay (F_3) and at the first zone of the primary distance relay (F_4):

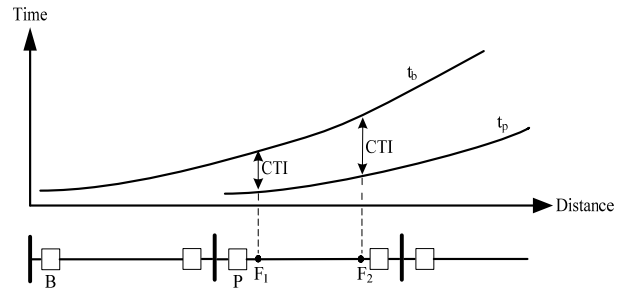

Fig. 1 Selectivity illustration for DOCRs.

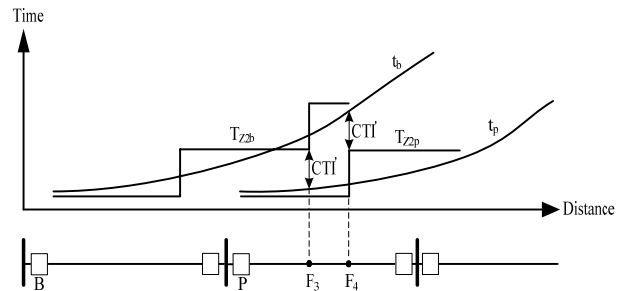

Fig. 2 Selectivity illustration for D&DOCRs.

$$T_{Z2b} - t_p^{F_3} \geq CTI' \quad (4)$$

$$t_b^{F_4} - T_{Z2p} \geq CTI'$$

where $t_p^{F_3}$ and T_{Z2b} are the operating time of the primary overcurrent relay for the faults at the end of the second zone of the backup distance relay, and the operating time of the second zone of the backup distance relay, respectively. Besides, T_{Z2p} and $t_b^{F_4}$ indicate the operating time of the second zone of the primary distance relay and the operating time of the overcurrent backup relay, respectively, for the faults at the end of the first zone of the primary distance relay. CTI' is the coordination time interval, typically selected between 0.2 to 0.5 seconds which may be different from the CTI . Based on Eq. (4), the selectivity constraints are satisfied if the backup DOCR operates slower than the second zone of the primary distance relay, and the primary DOCR operates faster than the second zone of the backup distance relay, as well.

2.1.2 Relay Settings Constraints

The time multiplier settings and the pickup currents of the DOCRs are limited to lower and upper bounds. These limits are presented below,

$$\begin{aligned} \text{TMS}_i^{\min} &\leq \text{TMS}_i \leq \text{TMS}_i^{\max} \\ \max(I_{\text{load}_i}^{\max}, I_{\text{set}_i}^{\min}) &\leq I_{\text{set}_i} \leq \min(I_{\text{fault}_i}^{\min}, I_{\text{set}_i}^{\max}) \end{aligned} \quad (5)$$

where $I_{\text{set}_i}^{\max}$ and $I_{\text{set}_i}^{\min}$ are the maximum and minimum pickup current settings of the i^{th} relay, respectively,

while $I_{load_i}^{max}$ and $I_{fault_i}^{min}$ indicate the maximum load current and minimum fault current passing through the i^{th} relay, respectively. Moreover, TMS_i^{max} and TMS_i^{min} represent the maximum and minimum time multiplier settings of the i^{th} relay, respectively.

2.2 Effect of the Pilot Protection on the D&DOCRs Coordination Problem

Pilot protection schemes increase the fault clearance speed along the protected transmission lines. There are different schemes of pilot protection from the view point of transmit and trip logics, including Directional Comparison Blocking (DCB), Directional Comparison UnBlocking (DCUB), Permissive Overreaching Transfer Trip (POTT), Permissive Underreaching Transfer Trip (PUTT), Direct Underreaching Transfer Trip (DUTT), and line current differential [2]. In this paper, it is assumed that the distance protection of the transmission lines is equipped with the PUTT scheme. This scheme, considering the practical aspects, is more suitable for long and medium transmission lines. In these transmission lines, the fault resistance is usually much smaller than the line impedance. Therefore, extension of the first zone to prevent unwanted operation of the distance relay is not required. In this situation, it is more appropriate if the pilot protection scheme only operates against the faults occurring on the protected line, in order to avoid the unwanted operation of the protection system in case of the faults on the adjacent line. In the PUTT scheme, if a fault is detected in the first zone, a trip signal is sent to the local breaker. In addition to that, a permissive trip signal is sent to the remote bus breaker. The remote bus breaker operates by receiving the permissive signal, if its relay finds the fault inside its second zone. The PUTT does not send a permissive signal for out-of-protected zone faults since the under-reaching element is used to send the signal in this scheme [19]. Therefore, the distance relay in the remote bus can clear the fault much faster than T_{Z2} , if the fault occurs beyond the first zone. This concept can be used in the D&DOCRs coordination to reduce the operating times of the DOCRs and the T_{Z2} s of the distance relays. Considering this concept in the coordination problem results in the selectivity constraints between the backup DOCRs and the primary distance relay are defined based on the current of the faults at the end of the transmission lines instead those of the end of the first zones. According to Fig. 3, these selectivity constraints can be presented by Eq. (6). In Fig. 3, T_{delay} is defined as the time delay required for clearing the faults between the end of the first zone of the distance relay and the remote bus. This delay is almost one or two cycles [2], much less than the operating times of the backup DOCRs for clearing the faults occurring at the end of the first zones of the primary distance relays.

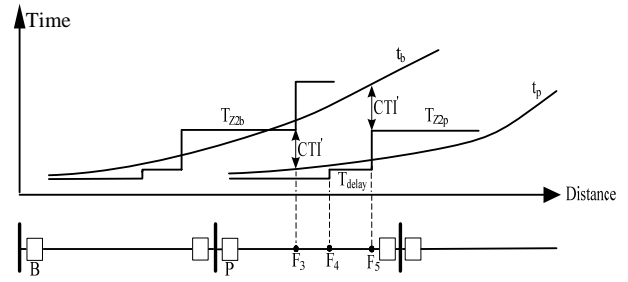

Fig. 3 Selectivity illustration for D&DOCRs considering pilot protection.

Therefore, if, for the faults at the point F_5 , the selectivity constraints between the backup DOCRs and the primary distance relays are satisfied, then these two groups of relays are coordinated at the end of the first zones (point F_4). It is worth noting that the both ends of the transmission lines beyond the first zone of the primary distance relays are protected almost instantaneously (with the delay of T_{delay}), which is considerable.

$$t_b^{F_5} - T_{Z2p} \geq CTI' \quad (6)$$

3 Simulation Results

Three case studies, including an 8-bus, the IEEE 14-bus and the IEEE 39-bus test systems, are used to evaluate the proposed method for the D&DOCRs coordination problem. In both cases, the TMS of each DOCR is considered as a continuous variable between 0.05 and 1.1. In order to analyze the proposed approach for the D&DOCRs coordination, without loss of generality, two time-current characteristics, including standard inverse ($K = 0.14$, $\alpha = 0.02$, and $\beta = 0$) and very inverse ($K = 13.5$, $\alpha = 1$, and $\beta = 0$), are considered for the operating characteristics of the DOCRs, based on the IEC standard. In this paper, the hybridized genetic algorithm and linear programming (HGA), proposed in [20], is applied with some modifications to obtain the optimal settings of the distance and overcurrent relays. In this algorithm, at first, I_{set} s are randomly selected in accordance with the limits of the pickup currents. Therefore, this nonlinear problem is converted to a linear one. Then, the T_{Z2} s and TMS s are obtained for all D&DOCRs in the LP sub-problem. If this sub-problem does not converge for some values of I_{set} , a penalty is added to the objective function. The LP sub-problem is called repeatedly by the GA routine.

3.1 Case I: 8-Bus Test System

The proposed approach for the D&DOCRs coordination, considering the pilot protection, is first implemented on the 8-bus test system shown in Fig. 4. This system is a 150 kV system that consists of 7 lines, 2 generators, and 2 transformers. The system data can be found in [21].

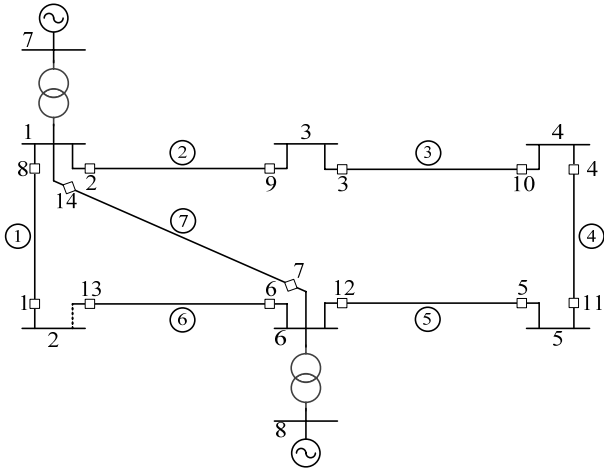

Fig. 4 Single line diagram of the 8-bus test system.

Furthermore, 14 distance relays as well as 14 DOCRs are considered the protection of the transmission lines. Nine discrete pickup current settings, including 0.5, 0.75, 1, 1.25, 1.5, 1.75, 2, 2.25, and 2.5 are assumed for all overcurrent relays.

The optimal values of the T_{Z2S} , TMS s and I_{set} s for D&DOCRs, considering and ignoring the pilot protection, are calculated and presented in Table 1, when the standard inverse characteristic is used for the operating times of the DOCRs. Based on the presented results in this table, it can be concluded that the objective function decreases from 12.7153 to 12.3504 seconds (2.87% reduction) when the pilot protection is considered in the coordination problem. Furthermore, the average of the T_{Z2S} s decreases from 0.5968 to 0.5822 seconds (2.45% reduction) and the sum of the operating times of the DOCRs is reduced from 4.3597 to 4.2 seconds (3.67% reduction). The convergence curve of the HGA for the 8-bus test system is shown in Fig. 5. According to Fig. 5, it can be seen that in both cases, i.e. with and without considering the pilot protection in the coordination problem, the HGA converges successfully.

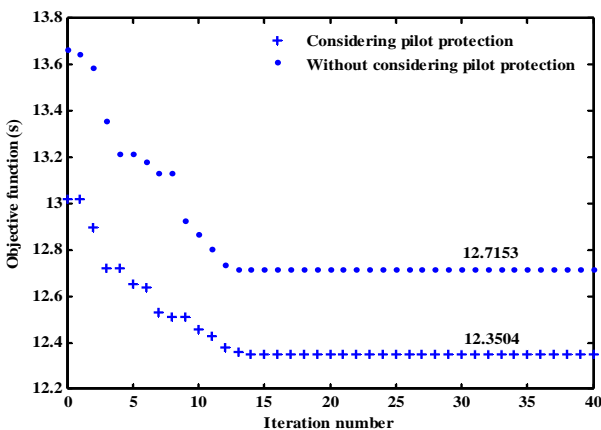

Fig. 5 Convergence of HGA for the 8-bus test system considering standard inverse characteristic for DOCRs.

In order to investigate the effects of the operating characteristics of the DOCRs on the reduction rate of the average of the T_{Z2S} s and the sum of the operating times of DOCRs, the coordination problem is re-solved considering very inverse characteristics for DOCRs. Table 2 reports the optimal settings of the D&DOCRs for this condition. According to Table 2, the average T_{Z2} and the sum of the operating times of DOCRs are reduced by 0.48% and 0.76%, respectively.

Table 1 Optimal settings of D&DOCRs for 8-bus test system considering standard inverse characteristic for DOCRs.

Relay No.	Without Considering Pilot Protection			With Considering Pilot Protection		
	I_{set}	TMS	T_{Z2}	I_{set}	TMS	T_{Z2}
1	2	0.0511	0.7399	2	0.0500	0.7074
2	2.5	0.1530	0.6557	2.5	0.1438	0.6149
3	2.5	0.1279	0.5061	2.5	0.1164	0.5061
4	2.25	0.0531	0.4575	2.25	0.0531	0.4575
5	1	0.0500	0.6670	1	0.0500	0.6471
6	2.5	0.0937	0.4723	2.5	0.0871	0.4664
7	2.5	0.1322	0.7399	2.5	0.1266	0.7074
8	2.5	0.0868	0.4779	2.5	0.0846	0.4779
9	1.5	0.0500	0.6541	1.5	0.0500	0.6405
10	2.5	0.0500	0.4477	2.5	0.0500	0.4477
11	2.5	0.0931	0.5022	2.5	0.0895	0.5022
12	2.5	0.1470	0.6102	2.5	0.1407	0.5942
13	2	0.0500	0.7126	2	0.0500	0.6906
14	2.5	0.1286	0.7126	2.5	0.1247	0.6906
OF	12.7153			12.3504		
$\sum_{i=1}^n t_i$	4.3597			4.2000		
Average T_{Z2S}	0.5968			0.5822		

Table 2 Optimal setting of D&DOCRs for 8-bus test system considering very inverse characteristic for DOCRs.

Relay No.	Without considering Pilot Protection			With Considering Pilot Protection		
	I_{set}	TMS	T_{Z2}	I_{set}	TMS	T_{Z2}
1	1.25	0.0576	0.5402	1.25	0.0569	0.5331
2	2.5	0.1511	0.5084	2.5	0.1480	0.4966
3	2.5	0.1341	0.4364	2.5	0.1289	0.4364
4	1.75	0.0572	0.4391	1.75	0.0572	0.4391
5	1	0.0500	0.4170	1	0.0500	0.4144
6	2.5	0.0771	0.3601	2.5	0.0768	0.3582
7	2.5	0.0962	0.5402	2.5	0.0950	0.5331
8	2.5	0.0720	0.3714	2.5	0.0720	0.3714
9	1.5	0.0500	0.4177	1.5	0.0500	0.4177
10	2	0.0501	0.4228	2	0.0501	0.4228
11	2.5	0.0806	0.4310	2.5	0.0806	0.4310
12	2.5	0.1521	0.4879	2.5	0.1521	0.4879
13	1.25	0.0578	0.5332	1.25	0.0578	0.5332
14	2.5	0.0965	0.5332	2.5	0.0965	0.5332
OF	8.7993			8.7509		
$\sum_{i=1}^n t_i$	2.3607			2.3427		
Average T_{Z2S}	0.4599			0.4577		

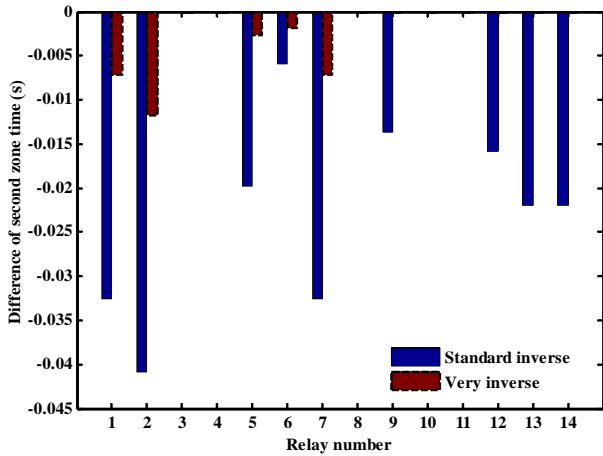

Fig. 6 Difference of T_{Z2} for different time-current characteristics of the DOCRs in the 8-bus test system.

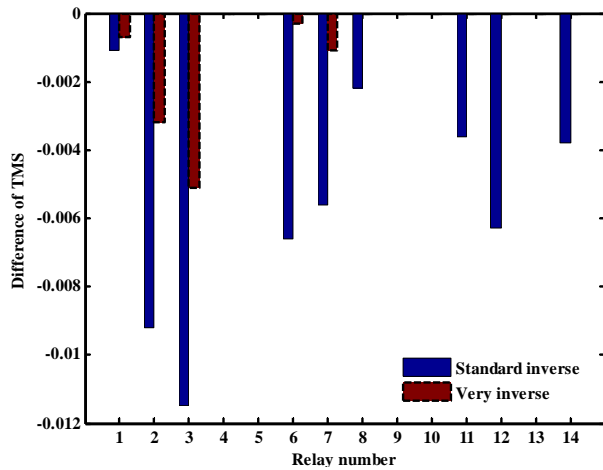

Fig. 7 Difference of TMS s for different time-current characteristics of DOCRs in the 8-bus test system.

According to the aforementioned results, the reduction rates of the average T_{Z2} s and the sum of the operating times of the DOCRs are reduced when the very inverse characteristics are adopted for the DOCRs instead of the standard ones. The reason behind this matter can be attributed to the smaller distance between the very inverse and the instantaneous characteristics in comparison with the distance corresponding to the standard characteristic.

Based on the presented results in Tables 1 and 2, the optimal settings for some relays are changed when the pilot protection is considered in the relay coordination. Fig. 6 shows the changes in the T_{Z2} for each distance relay, considering standard inverse and very inverse characteristics for the DOCRs. According to this figure, it can be seen that the T_{Z2} s of nine distance relays are decreased when standard inverse characteristics are adopted for the DOCRs, whereas in case of using very inverse characteristics for the DOCRs, the T_{Z2} s of five distance relays are decreased. Furthermore, for both

characteristics the maximum change of the T_{Z2} is related to distance relay #2, reduced by 0.0408 and 0.0118 seconds in case of the pilot protection for the standard inverse and very inverse characteristics, respectively.

The change of the TMS for each DOCR in case of the standard inverse and very inverse characteristics is shown in Fig. 7, when the pilot protection is considered in the relay coordination. Based on Fig. 7, the TMS s of nine and five DOCRs are decreased, considering standard inverse and very inverse characteristics for the DOCRs, respectively. Moreover, the maximum change in the TMS occurs for overcurrent relay #3, reduced by 0.0115 and 0.0051 in case of the pilot protection for the standard inverse and very inverse characteristics, respectively.

3.2 Case II: IEEE 14-Bus Test System

The IEEE 14-bus test system, illustrated in Fig. 8, is the second test system that the proposed relay coordination approach is applied to it. This system, with the voltage levels of 132/33 kV, consists of 16 lines, 5 synchronous machines including 2 synchronous generators and 3 synchronous compensators, and 3 transformers. It is assumed that the lines are protected by 32 distance relays as well as 32 DOCRs. The IEEE 14-bus test system data are presented in [22]. Since the secondary currents of the current transformers are set to the nominal value of 5 amperes, the pickup currents of all overcurrent relays are considered as discrete values in the range of 2.5 to 12.5 amperes, with the steps of 1.25 amperes.

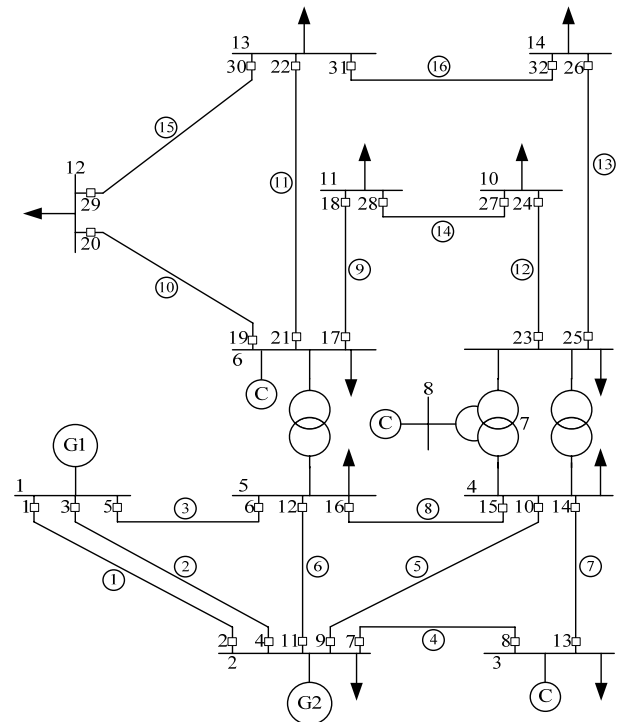

Fig. 8 Single line diagram of the IEEE 14-bus test system.

Table 3 Optimal settings of D&DOCRs for the IEEE 14-bus test system considering standard inverse characteristic for DOCRs.

Relay No.	Without Considering Pilot Protection			With Considering Pilot Protection		
	I_{set}	TMS	T_{Z2}	I_{set}	TMS	T_{Z2}
1	5	0.0500	0.4769	5	0.0500	0.4708
2	12.5	0.0500	0.4598	12.5	0.0500	0.4598
3	5	0.0500	0.4769	5	0.0500	0.4708
4	12.5	0.0500	0.4598	12.5	0.0500	0.4598
5	7.5	0.0500	0.5023	7.5	0.0500	0.5029
6	10	0.0500	0.4262	10	0.0500	0.4262
7	10	0.0511	0.5926	10	0.0500	0.5744
8	12.5	0.0768	0.4450	12.5	0.0787	0.4450
9	8.75	0.0500	0.5173	8.75	0.0500	0.5173
10	7.5	0.0500	0.4769	7.5	0.0500	0.4708
11	12.5	0.0500	0.5023	12.5	0.0500	0.5029
12	6.25	0.0517	0.4769	6.25	0.0512	0.4708
13	12.5	0.1163	0.5173	12.5	0.1109	0.5173
14	12.5	0.0500	0.4693	12.5	0.0502	0.4760
15	12.5	0.1073	0.4395	12.5	0.1073	0.4395
16	11.25	0.0516	0.4526	11.25	0.0517	0.4536
17	12.5	0.1758	0.8772	12.5	0.1636	0.8140
18	12.5	0.1009	0.6857	12.5	0.0997	0.6769
19	11.25	0.1049	0.5865	12.5	0.0959	0.5796
20	6.25	0.0529	0.8223	6.25	0.0503	0.7790
21	12.5	0.1485	0.7433	12.5	0.1458	0.7286
22	12.5	0.1182	0.8223	12.5	0.1124	0.7790
23	12.5	0.1892	0.6980	12.5	0.1795	0.6780
24	12.5	0.1715	0.6872	12.5	0.1599	0.6357
25	12.5	0.1155	0.7563	12.5	0.1033	0.6710
26	12.5	0.1788	0.7796	12.5	0.1721	0.7497
27	12.5	0.1246	0.6401	12.5	0.1195	0.6349
28	12.5	0.1915	0.7199	12.5	0.1736	0.6848
29	12.5	0.0903	0.7433	12.5	0.0887	0.7286
30	12.5	0.0587	0.3381	12.5	0.0577	0.3314
31	12.5	0.1281	0.8000	12.5	0.1247	0.7776
32	12.5	0.1251	0.5802	12.5	0.1059	0.5616
OF	27.9678			27.0965		
$\sum_{i=1}^n t_i$	8.9559			8.6286		
Average $T_{Z2}s$	0.5929			0.5771		

The optimal settings for the distance and overcurrent relays are presented in Table 3, with and without considering the pilot protection in the coordination problem, when the standard inverse characteristics are used as the operating time curves of the DOCRs. According to the presented results in Table 3, the pilot protection reduces the objective function value, the sum of the operating times of the DOCRs, and the average of the $T_{Z2}s$, from 27.9678, 8.9559 and 0.5929 to 27.0965, 8.6286 and 0.5771 seconds, respectively, corresponding to the reduction rates of 3.12%, 3.65% and 2.67%, respectively. The HGA convergence curve for this test system is depicted Fig. 9, with and without the pilot protection in the coordination problem.

The optimal settings of the D&DOCRs are summarized in Table 4 when the very inverse characteristic is assumed for the operating characteristics of the DOCRs.

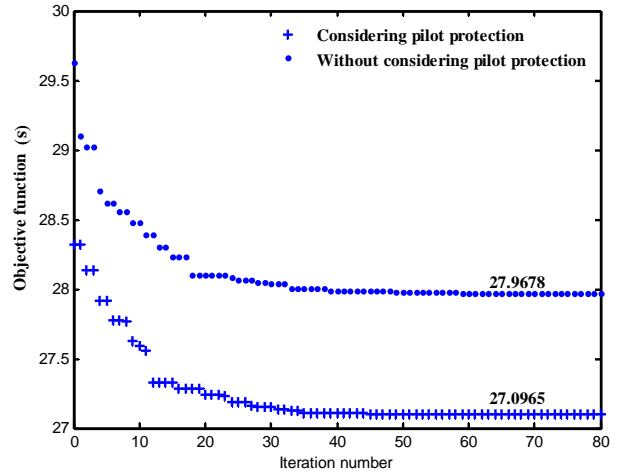

Fig. 9 Convergence of HGA for the IEEE 14-bus test system considering standard inverse characteristic for DOCRs.

Table 4 Optimal settings of D&DOCRs for the IEEE 14-bus test system considering very inverse characteristic for DOCRs.

Relay No.	Without Considering Pilot Protection			With Considering Pilot Protection		
	I_{set}	TMS	T_{Z2}	I_{set}	TMS	T_{Z2}
1	5	0.0500	0.3510	5	0.0500	0.3467
2	10	0.0500	0.4429	10	0.0500	0.4429
3	5	0.0500	0.3510	5	0.0500	0.3467
4	10	0.0500	0.4429	10	0.0500	0.4429
5	7.5	0.0500	0.4024	7.5	0.0500	0.4028
6	10	0.0500	0.3881	10	0.0500	0.3881
7	6.25	0.0529	0.4313	6.25	0.0514	0.4132
8	12.5	0.0592	0.3429	12.5	0.0614	0.3429
9	6.25	0.0500	0.4183	6.25	0.0500	0.4183
10	7.5	0.0500	0.3510	7.5	0.0500	0.3467
11	8.75	0.0523	0.4094	8.75	0.0524	0.4094
12	6.25	0.0500	0.3510	6.25	0.0500	0.3467
13	12.5	0.1135	0.4183	12.5	0.1046	0.4183
14	7.5	0.0572	0.3315	7.5	0.0577	0.3363
15	12.5	0.1471	0.4094	12.5	0.1471	0.4094
16	7.5	0.0582	0.3395	7.5	0.0583	0.3407
17	12.5	0.1226	0.5511	11.25	0.1326	0.5181
18	12.5	0.0533	0.4048	12.5	0.0533	0.4048
19	11.25	0.0690	0.3525	11.25	0.0690	0.3525
20	6.25	0.0500	0.4778	6.25	0.0500	0.4660
21	12.5	0.1081	0.4386	12.5	0.1081	0.4386
22	12.5	0.0600	0.4778	12.5	0.0592	0.4660
23	12.5	0.1813	0.4367	12.5	0.1813	0.4367
24	12.5	0.1658	0.4105	12.5	0.1614	0.3943
25	12.5	0.0643	0.4444	12.5	0.0593	0.4011
26	12.5	0.1413	0.4932	12.5	0.1413	0.4932
27	12.5	0.0804	0.3867	12.5	0.0804	0.3867
28	12.5	0.1551	0.4615	12.5	0.1405	0.4547
29	11.25	0.0514	0.4386	11.25	0.0514	0.4386
30	11.25	0.0517	0.3000	11.25	0.0517	0.3000
31	12.5	0.0720	0.4841	12.5	0.0720	0.4841
32	12.5	0.0672	0.3343	12.5	0.0553	0.3343
OF	16.5296			16.2997		
$\sum_{i=1}^n t_i$	3.4561			3.3780		
Average $T_{Z2}s$	0.4086			0.4038		

Based on the presented results in Table 4, the pilot protection reduces the objective function, the sum of the operating times of the DOCRs, and the average of the T_{Z2} s, from 16.5296, 3.4561 and 0.4086 to 16.2997, 3.3780 and 0.4038 seconds, respectively, with the reduction rates of 1.39%, 2.26% and 1.19%, respectively. By comparing the presented results in Tables 3 and 4, it can be seen that if the standard inverse characteristics are considered for the operating times of the DOCRs, more reduction is experienced by the aforementioned parameters of the DOCRs.

The changes of the T_{Z2} s and TMS s in the IEEE 14-bus test system for the standard inverse and very inverse characteristics are shown in Figs. 10 and 11, respectively, when the pilot protection is considered.

Based on Fig. 10, for both standard inverse and very inverse characteristics, the maximum change of the T_{Z2} corresponds to distance relay #25, which is decreased by 0.0853 and 0.0433 seconds, respectively, with the pilot protection. According to Fig. 11, for the standard inverse characteristic, the maximum change of the TMS relates to overcurrent relay #32 with the pilot protection. In this case, the TMS of this relay is reduced by 0.0192. Furthermore, for the very inverse characteristic, the maximum change of TMS is occurred for overcurrent relay #28, reduced by 0.0146, with the pilot protection. Moreover, based on Figs. 10 and 11, although T_{Z2} s and TMS s of some relays are increased, but the rates of increase of these parameters are small, and so, the sum of the operating times of the distance and overcurrent relays is decreased in case of the pilot protection.

3.3 Case III: IEEE 39-Bus Test System

The third system is the IEEE 39-bus test system which is shown in Fig. 12 that is well known as 10-machine New-England Power System. The voltage level of this system is 345 kV that consists of 16 lines and 9 transformers.

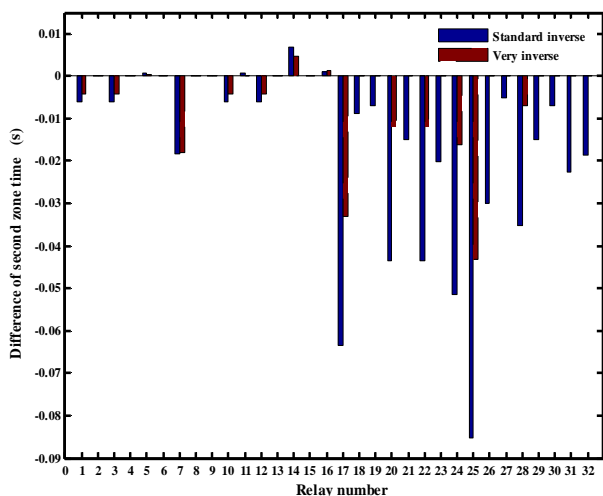

Fig. 10 Difference of T_{Z2} for different time-current characteristics of DOCRs in the IEEE 14-bus test system.

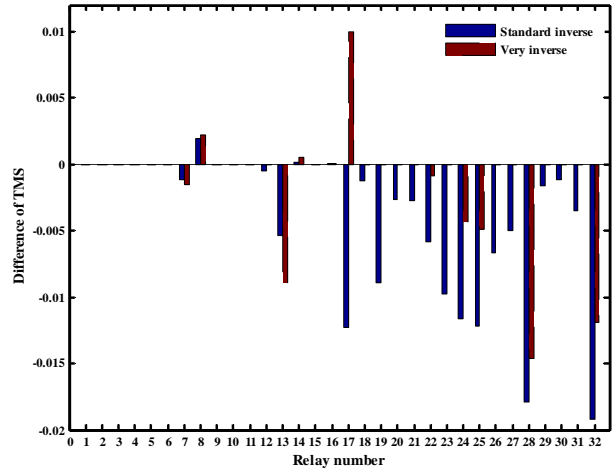

Fig. 11 Difference of TMS for different time-current characteristics of DOCRs in the IEEE 14-bus test system.

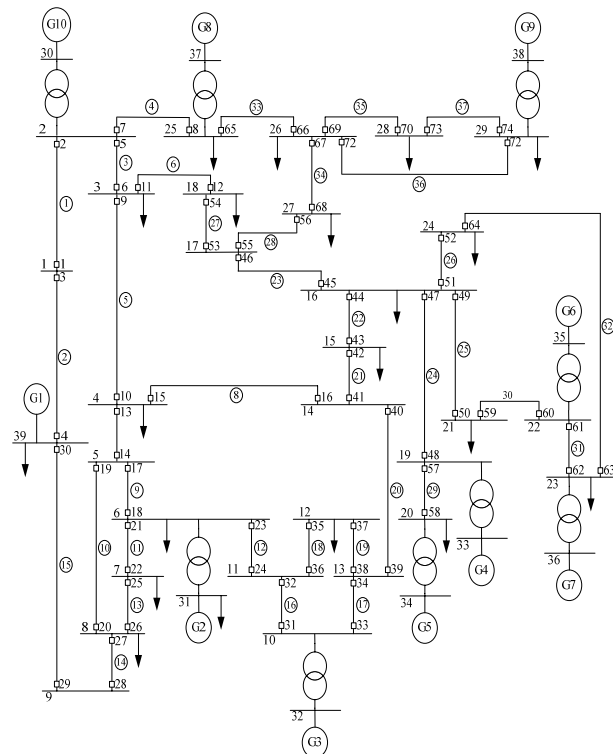

Fig. 12 Single line diagram of the IEEE 39-bus test system.

Also, 74 distance relays, as well as 74 DOCRs are used for protection of the transmission lines. The IEEE 39-bus test system data are taken from [23].

Table 5 shows the optimal settings of the D&DOCRs when the standard inverse characteristic is assumed for the operating characteristics of the DOCRs. It can be seen that using pilot protection cause to reduce the objective function, the sum of the operating times of the DOCRs, and the average of the T_{Z2} s, from 64.2980, 20.5250, and 0.5915, to 62.7730, 19.8170, and 0.5805 seconds, respectively.

Table 5 Optimal settings of D&DOCRs for the IEEE 39-bus test system considering very inverse characteristic for DOCRs.

Relay No.	Without Considering Pilot Protection			With Considering Pilot Protection			Relay No.	Without Considering Pilot Protection			With Considering Pilot Protection		
	I_{set}	TMS	T_{Z2}	I_{set}	TMS	T_{Z2}		TMS	T_{Z2}	TMS	T_{Z2}	I_{set}	TMS
1	1021	0.0623	0.6149	1019	0.0546	0.5499	38	838	0.0500	0.3718	738	0.0513	0.3715
2	1609	0.0500	0.5383	1115	0.0596	0.4843	39	1714	0.0500	0.5648	1489	0.0500	0.5528
3	797	0.0500	0.4805	627	0.0519	0.4772	40	1983	0.0620	0.6909	2057	0.0549	0.7136
4	2952	0.0500	0.5798	2639	0.0500	0.5313	41	1337	0.0682	0.6324	1821	0.0500	0.6843
5	1383	0.0926	0.6212	2379	0.0500	0.6114	42	1682	0.0500	0.6895	1590	0.0500	0.6529
6	1607	0.0519	0.5459	1365	0.0636	0.5499	43	1130	0.0526	0.5861	1284	0.0500	0.5828
7	2578	0.0500	0.5440	2607	0.0500	0.5581	44	2979	0.0500	0.6027	2641	0.0534	0.5774
8	1314	0.0642	0.6402	1342	0.0536	0.5820	45	2805	0.0500	0.6090	2784	0.0500	0.5945
9	1401	0.0702	0.6161	1505	0.0599	0.6133	46	1933	0.0500	0.5575	1641	0.0550	0.5436
10	1475	0.0505	0.6212	1541	0.0500	0.6114	47	1406	0.0679	0.4587	1561	0.0562	0.4094
11	2358	0.0500	0.6800	2308	0.0501	0.6780	48	1403	0.0500	0.5861	1114	0.0666	0.5828
12	1294	0.0590	0.6542	1496	0.0500	0.5742	49	2165	0.0614	0.6009	2461	0.0500	0.5915
13	1931	0.0507	0.6411	1856	0.0528	0.6526	50	804	0.0660	0.5861	1021	0.0500	0.5828
14	1794	0.0500	0.5878	1824	0.0500	0.6058	51	1818	0.0787	0.5051	2254	0.0659	0.5110
15	1640	0.0579	0.6895	1225	0.0778	0.6529	52	620	0.0553	0.6190	604	0.0570	0.6152
16	1595	0.0500	0.6161	1514	0.0500	0.6133	53	2362	0.0537	0.5771	2427	0.0501	0.5702
17	1919	0.0500	0.6576	1821	0.0548	0.6669	54	1406	0.0640	0.6581	1712	0.0500	0.6137
18	1987	0.0575	0.5655	1983	0.0581	0.5721	55	2132	0.0520	0.5858	2230	0.0500	0.5831
19	1489	0.0568	0.5651	1466	0.0574	0.5620	56	1029	0.0500	0.6507	773	0.0699	0.6082
20	720	0.0671	0.6411	902	0.0500	0.6526	57	1464	0.0500	0.3000	1075	0.0500	0.3000
21	2284	0.0500	0.6678	1567	0.0693	0.5493	58	933	5.5000	0.6258	933	5.5000	0.6413
22	920	0.0500	0.6102	920	0.0500	0.6137	59	1331	0.0602	0.5613	1551	0.0500	0.5446
23	2501	0.0500	0.6926	2538	0.0500	0.6756	60	1869	0.0500	0.5909	1533	0.0554	0.5733
24	1754	0.0500	0.6102	1589	0.0503	0.6137	61	820	0.0901	0.5193	1160	0.0683	0.5018
25	1608	0.0500	0.5316	1002	0.0614	0.4686	62	1588	0.0500	0.6207	1723	0.0500	0.5756
26	1625	0.0561	0.5302	1697	0.0533	0.5302	63	1096	0.0500	0.6155	1030	0.0500	0.6167
27	815	0.0866	0.4948	1084	0.0550	0.4822	64	1081	0.0537	0.6235	1197	0.0500	0.6707
28	1453	0.0500	0.5651	1425	0.0500	0.5620	65	1466	0.0523	0.6505	1433	0.0556	0.6746
29	506	0.0594	0.5060	587	0.0504	0.4782	66	1146	0.0500	0.6623	985	0.0533	0.5944
30	2671	0.0500	0.6174	2456	0.0528	0.6082	67	1560	0.0500	0.6303	1620	0.0500	0.6428
31	2065	0.0575	0.6747	1526	0.0778	0.6202	68	1253	0.0565	0.5873	1116	0.0625	0.5522
32	1983	0.0514	0.6638	1791	0.0566	0.6247	69	726	0.0766	0.6453	722	0.0799	0.6730
33	1917	0.0657	0.6327	2034	0.0565	0.5680	70	402	0.0500	0.6505	407	0.0500	0.6746
34	1771	0.0500	0.6819	1827	0.0500	0.6759	71	474	0.0741	0.5474	658	0.0513	0.5563
35	177	0.0500	0.6926	176	0.0500	0.6756	72	437	0.0500	0.6505	433	0.0500	0.6746
36	463	0.0762	0.3808	717	0.0543	0.3820	73	693	0.0500	0.4459	724	0.0500	0.4435
37	197	0.0500	0.6909	199	0.0501	0.7136	74	1082	0.0500	0.4601	1111	0.0500	0.4630
OF	64.2980			62.7730									
$\sum_{i=1}^n t_i$	20.5250			19.8170									
Average T_{Z2S}	0.5915			0.5805									

It is worth noting that since T_{delay} is very close to zero (2 cycles at maximum), the 20% of the both ends of the lines are protected almost instantaneously, in comparison with the delay reaction due to the operating time of the second zone of the primary distance relay or the operating time of the backup DOCRs for clearing the faults occurring at the mentioned locations.

4 Conclusion

In this paper, a new formulation is proposed for the distance and directional overcurrent relays coordination, considering the pilot protection in interconnected power systems. In the proposed approach, the selectivity constrains between the primary distance and backup overcurrent relays are modeled based on the faults occurring at the end of the transmission lines. In this

study, the I_{set} s and TMS s of the DOCRs are assumed as discrete and continuous optimization variables, respectively. Furthermore, different T_{Z2} s are considered as the optimization variables for the distance relays. Then, a hybrid genetic algorithm is applied to obtain the optimal settings of the D&DOCRs. In order to evaluate the proposed D&DOCRs coordination approach, three test systems, namely an 8-bus, the IEEE 14-bus and the IEEE 39-bus test systems, are used. Based on the obtained results, it can be concluded that the average T_{Z2} s for the distance relays and the operating times of the DOCRs are reduced when the pilot protection is included in the D&DOCRs coordination problem. Furthermore, the 20% of the both ends of the transmission lines are protected almost instantaneously, which is significant.

References

- [1] E. Bartosiewicz, R. Kowalik and M. Januszewski, "Overview and Test Results of Modern Pilot Schemes for Coordination of Line Distance Protection Relays", *IEEE International Conference on Environment and Electrical Engineering*, pp. 191–196, May 2013.
- [2] IEEE Working Group D8 of the Line Protection Subcommittee D, Power System Relaying Committee, "Justifying Pilot Protection on Transmission Lines", *63rd Annual Conf. for Protective Relay Engineers*, pp. 1–31, March 2010.
- [3] F. Namdari, S. Jamali and P. A. Crossley, "Power Differential based Wide Area Protection", *Iranian Journal of Electrical & Electronic Engineering*, Vol. 1, No. 3, pp. 53–65, Jul. 2005.
- [4] L. G. Perez, A. J. Urdaneta, E. Sorrentino, F. Garayar, A. Urizar, J. C. Ledzema, G. D. Alcala, N. Carrion, C. Canache, J. Fernandez, O. Sanz and F. Guevara, "Comparison of time coordination criteria for a subtransmission system protection scheme", *IEEE International Caracas Conference on Device Circuit and System*, pp. 314–319, Mar. 1998.
- [5] L. G. Perez and A. J. Urdaneta, "Optimal coordination of directional overcurrent relays considering definite time backup relaying", *IEEE Transaction Power Delivery*, Vol. 14, No. 4, pp. 1276–1284, Oct. 1999.
- [6] C. W. So and K. K. Li, "Time coordination method for power system protection by evolutionary algorithm", *IEEE Transactions on Industry Applications*, Vol. 36, No. 5, pp. 1235–1240, Sep./Oct. 2000.
- [7] L. G. Perez and A. J. Urdaneta, "Optimal computation of distance relays second zone timing in a mixed protection scheme with directional overcurrent relays", *IEEE Transactions on Power Delivery*, Vol. 16, No. 3, pp. 385–388, Jul. 2001.
- [8] S. Jamali and M. Pourtandorost, "New approach to coordination of distance relay zone-2 with overcurrent protection using linear programming methods", *IEEE International Universities Power Engineering Conference*, pp. 827–831, Sep. 2004.
- [9] M. Khederzadeh, "Back-up protection of distance relay second zone by directional overcurrent relays with combined curves", *IEEE Power Engineering Society General Meeting*, pp. 1–6, 2006.
- [10] R. M. Chabanloo, H. A. Abyaneh, S. S. H. Kamangar and F. Razavi, "A new genetic algorithm method for optimal coordination of overcurrent and distance relays considering various characteristics for overcurrent relay", *IEEE International Power and Energy Conference*, pp. 569–573, Dec. 2008.
- [11] H. A. Abyaneh, S. S. H. Kamangar, F. Razavi and R. M. Chabanloo, "A new genetic algorithm method for optimal coordination of overcurrent relays in a mixed protection scheme with distance relays", *IEEE International Universities Power Engineering Conference*, pp. 1–5, Sep. 2008.
- [12] S. S. H. Kamangar, H. A. Abyaneh, F. Razavi and R. M. Chabanloo, "Optimal combined overcurrent and distance relays coordination using a new genetic algorithm method", *Int. Journal of Innovations in Energy System and Power*, Vol. 5, No. 1, pp. 17–21, Apr. 2010.
- [13] R. M. Chabanloo, H. A. Abyaneh, S. S. H. Kamangar and F. Razavi, "Optimal combined overcurrent and distance relays coordination incorporating intelligent overcurrent relays characteristics selection", *IEEE Trans. on Power Delivery*, Vol. 26, No. 3, pp. 1381–1391, Jul. 2011.
- [14] J. Sadeh, V. Aminotojari and M. Bashir, "Optimal coordination of overcurrent and distance relays with hybrid genetic algorithm", *IEEE International Conference on Environment and Electrical Engineering*, pp. 1–5, May 2011.
- [15] J. Sadeh, V. Aminotojari, and M. Bashir, "Coordination of overcurrent and distance relays using hybrid particle swarm optimization", *IEEE International Conference on Advanced Power System Automation and Protection*, pp. 1130–1134, Oct. 2011.
- [16] A. A. M. Birjandi and M. Pourfallah, "Optimal coordination of overcurrent and distance relays by a new particle swarm optimization method", *International Journal of Energy and Advanced Technol*, Vol. 1, No. 2, pp. 93–98, Dec. 2011.
- [17] Z. Moravej, M. Jazaeri and M. Gholamzadeh, "Optimal coordination of distance and overcurrent relays in series compensated systems based on MAPSO", *Energy Conversion and Management*, Vol. 56, pp. 140–151, Apr. 2012.
- [18] M. Farzinfar, M. Jazaeri and F. Razavi, "A new approach for optimal coordination of distance and directional over-current relays using multiple embedded crossover PSO", *International Journal of Electric Power and Energy System*, Vol. 61, pp. 620–628, Oct. 2014.
- [19] E. O. Schweitzer and J. J. Kumm, "Statistical Comparison and Evaluation of Pilot Protection Schemes", *23th Annual Western Protective Relay Conference*, pp. 1–20, Oct. 1996.
- [20] A. S. Noghabi, J. Sadeh and H. R. Mashhadi, "Considering Different Network Topologies in Optimal Overcurrent Relay Coordination Using a Hybrid GA", *IEEE Trans. on Power Delivery*, Vol. 24, No. 4, pp. 1857–1863, Oct. 2009.
- [21] A. S. Braga, and J. T. Saraiva, "Coordination of overcurrent directional relays in meshed networks using the simplex method", *IEEE Mediterranean*

Electrotechnical Conference, pp. 1535–1538, May 1996.

- [22] R. D. Christie, *Power Systems Test Case Archive*, [online]. Available: <http://www.ee.washington.edu/research/pstca>.
- [23] A. Pai, *Energy Function Analysis for Power System Stability*, Springer US, 2012.



Yaser Damchi was born in Babol, Iran in 1983. He received the B.Sc. and M.Sc. degree in Electrical Power Engineering from Zanzan University, Zanzan Iran and Ferdowsi University of Mashhad, Mashhad, Iran in 2006 and 2010, respectively. He is currently pursuing the Ph.D. degree in Electrical Power Engineering at Ferdowsi

University of Mashhad, Mashhad, Iran. His research interests are power system protection and reliability.



Javad Sadeh was born in Mashhad, Iran in 1968. He received the B.Sc. and M.Sc. with honour both in Electrical Engineering from Ferdowsi University of Mashhad, Mashhad, Iran in 1990 and 1994, respectively and obtained his Ph.D. in Electrical Engineering from Sharif University of Technology, Tehran, Iran with the collaboration of

the electrical engineering laboratory of the Institute National Polytechnique de Grenoble (INPG), France in 2001. Currently, he is a professor at the Ferdowsi University of Mashhad, Mashhad, Iran. His research interests are power system protection, dynamics and operation.



Habib Rajabi Mashhadi was born in Mashhad, Iran, in 1967. He received the B.Sc. and M.Sc. degrees with honor from the Ferdowsi University of Mashhad, Mashhad, Iran, both in electrical engineering, and the Ph.D. degree from the Department of Electrical and Computer Engineering of Tehran University, Tehran, Iran, under

joint cooperation of Aachen University of Technology, Germany, in 2002. He is a professor of electrical engineering at Ferdowsi University of Mashhad and is with the Center of Excellence on Soft Computing and Intelligent Information Processing, Ferdowsi University of Mashhad. His research interests are power system operation and planning, power system economics, and biological computation.