

# A New Class of Resonant Discharge Drive Topology for Switched Reluctance Motor

M. Asgar\* and E. Afjei\*\*

**Abstract:** Switched reluctance motor (SRM) drive has a remarkable characteristic, high efficiency, and good controllability, which makes it attractive for high-speed applications. In this paper, the basic control strategy for a switched reluctance motor drive circuit is explained and then three different resonant discharge topologies for SRM drive circuit are proposed. Due to resonantly discharging of excess energy, these topologies provide faster rate of fall for the phase current, which permits the motor to operate at higher speeds. In the new circuits a capacitor is charged resonantly by the use of motor phase windings during the phase turn off periods and then discharged via an inductor and a diode during the next working strokes. Three different drive circuits utilizing this process are proposed. A detailed explanation and demonstration of the converter circuits have been presented.

**Keywords:** Switched Reluctance Motor Drive, Resonant Drive, SRM and Drive Circuit.

## 1 Introduction

SRM drives are attractive for use in many high performance industrial applications, with PWM used as an efficient means of power transfer, where high speed, torque and precision controls are required. In order to be able to run a SRM in high speeds some special considerations must be taken in drive circuit topology. One of those can be achieved by providing a path for faster discharge of current during the phase turn off time. This paper introduces three such topologies which serve such a purpose. In general, the essential features of the power switching circuit for each phase of reluctance motor are comprised of two parts namely [1], a controlled switch to connect the voltage source to the coil windings to build up the current and the other part is an alternative path for the current to flow when the switch is turned off, since the trapped energy in the phase winding can be used in the other strokes. In addition, this protects the switch from the high current produced by the energy trapped in the phase winding.

Fig. 1 shows a simple form of switching circuit for a switched reluctance motor [2]. The general equation governing the flow of stator current can be written for Fig. 1 as:

$$V = Ri + \frac{d\lambda}{dt} \quad (1)$$

where  $V$  is the voltage applied across the winding and  $\lambda$  is the flux linking the coil.

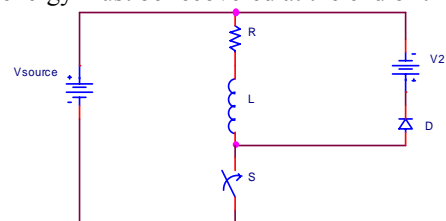
Considering a linear magnetic circuit and negligible resistance, Eq. (1) can be rewritten as:

$$V = L \frac{di}{dt} + i \frac{dL}{d\theta} \times \frac{d\theta}{dt} \quad (2)$$

Therefore, the rate of energy flow is given by

$$Vi = \frac{d}{dt} \left( \frac{1}{2} Li^2 \right) + \frac{i^2}{2} \times \frac{dL}{d\theta} \times \omega \quad (3)$$

The above equation indicates that for a reluctance motor the input electrical power goes partly to increase the stored magnetic energy  $\left( \frac{1}{2} Li^2 \right)$  and partly to provide mechanical output power  $\left( \frac{i^2}{2} \times \frac{dL}{d\theta} \times \omega \right)$ . The stored energy must be recovered at the end of the stroke.



**Fig. 1** A General Drive Circuit

Iranian Journal of Electrical & Electronic Engineering, 2009.

Paper first received 9 March 2009 and in revised form 2 Nov. 2009.

\* The Author is with the Department of Electrical and Computer Engineering, Shahid Beheshti University, Tehran, Iran.

E-mail: [majidasgar@gmail.com](mailto:majidasgar@gmail.com)

\*\* The Author is with the Department of Electrical and Computer Engineering, Shahid Beheshti University, Tehran, Iran.

E-mail: [e-afjei@sbu.ac.ir](mailto:e-afjei@sbu.ac.ir)

Some of proposed practical drive circuits for reluctance motors are a two-switch-per-pole circuit, N+1 transistors converter circuit for N-phase motor, Bifilar winding converter, C-dump topologies, Resonant drive circuit, and regenerative single-switch-per-phase converter, and many more for different purposes.

In a two-switch-per-pole converter, the upper transistor is used to control the amount of current through the winding, while the lower transistor synchronizes the proper operation of that phase with the rotor position by the use of a Hall Effect sensor. The excess energy is directed back through the diodes to the battery [3].

In an N+1 transistor converter circuit for N-phase motor only one transistor is common to all the phases for the control of current, while the other transistors are used for the proper operation of the phases. This type of converter circuit directs the excess energy back to the battery through a diode [4].

In a Bifilar winding converter arrangement the number of switches and diodes per phase is reduced by introducing a bifilar winding for each stator pole. It should be noted that in the bifilar connection the primary and the secondary circuits are wound together on each pole for maximum coupling. A current flows into the primary winding when the switching transistor is on. By turning the transistor off the primary current falls to zero. This establishes a corresponding current in the secondary winding so as to maintain constant flux linkages. This secondary current flows through a diode and returns the excess energy to the power supply [5,6].

The C-dump converters get their name from the fact that energy stored in the winding is dumped on a capacitor and used again in the second stroke. Several C-dump topologies have been implemented [7].

In a resonant converter circuit, stored energy of pole windings is dumped to a capacitor to rapidly turn the pole off. Then capacitor energy is transferred through a resonant circuit to DC power supply [8]. A topology which mentioned in [9] utilizes a resonant circuit which provides faster rate of fall for the phase current in a two switch per phase converter. This drive circuit permits the motor to operate at higher speeds. Another resonant drive circuit stated in [10] employs a capacitor connected in series with the motor bifilar winding for faster discharge current. The effect of different capacitor is analyzed.

In regenerative-single-switch per phase converter the source voltage is connected to the phase winding by turning two transistors on. When these two transistors are turned off, the energy stored in the phase winding is released to a capacitor. In this mode, the voltage across the winding reverses polarity and produces a current to charge the capacitor which causes faster rate of fall for the phase winding current. The energy transferred from pole winding to the capacitor is then discharged through a resistor by turning a transistor on [11].

## 2 The Models

### 2.1 The Basic Model

The principles of operation of two switches per phase switched reluctance motor drive have been widely explained and understood; hence it will not be explained here. It is appropriate, however to use a linear model of the motor with a two switches per phase, to develop simplified expressions for the current waveforms under different advancement of the phase turn on angles to show the discharging current waveform as well as its timing under different rotor position. Fig. 2 illustrates a 3-phase, 6 x 4 SRM drive showing only phase one winding and its drive circuit.

Although saturation plays an important role in obtaining the exact behavior of the SRM drive and also, is necessary for the detailed motor design, but analysis of magnetically linear SRM drive can provide useful and broad understanding of the influence of the many motor and drive parameters. Fig. 3 shows the variation of inductance with respect to the rotor position for only one pair of stator poles in an ideal linear motor shown in Fig. 2. The positions of rotor pole with respect to the stator pole corresponding to the different parts of inductance profile are also shown in Fig. 3.

The current flowing in the phase winding of Fig. 2 can be described by the following equation:

$$V_s = Ri + L(\theta) \frac{di}{dt} + i \frac{dL(\theta)}{d\theta} \omega \quad (4)$$

where,  $V_s$  is the source voltage,  $i$  is the phase current,  $R$  and  $L$  are resistance and inductance of the phase and  $\omega$  is the motor speed.

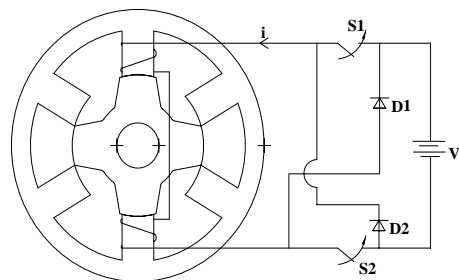


Fig. 2 A 6 x 4 SRM drive, showing the phase one winding and its drive circuit

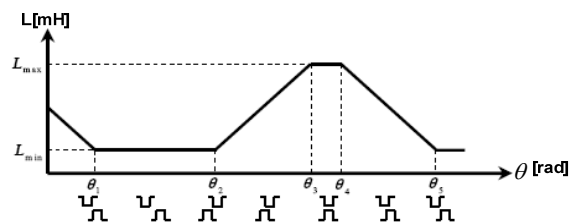


Fig. 3 Inductance variation of one motor phase

The solution to Eq. (1) yields the following result for the current,  $i$

$$i = \frac{V_s}{R + \frac{dL}{d\theta} \omega} + [I_0 - \frac{V_s}{R + \frac{dL}{d\theta} \omega}] e^{-\frac{t}{\tau}} \quad (5)$$

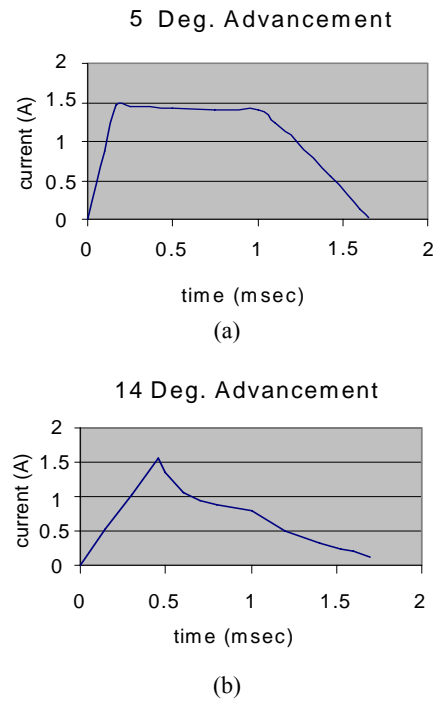
where;  $I_0$  is the initial current, and

$$\tau = \frac{L(\theta)}{R + \frac{dL(\theta)}{d\theta} \omega} \quad (6)$$

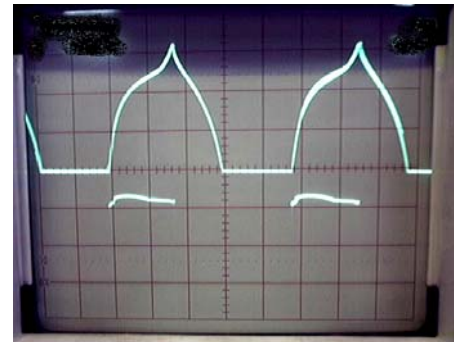
Fig. 4 shows the current waveforms for different advancements in conduction angle. It is worth mentioning here that, for comparison purposes, all the current curves have been plotted starting at  $t = 0$ .

In order to see the shape of the actual current waveforms under different turn on angles, a set of optical sensors, having adjustable positions with respect to rotor pole is fixed at the end of the 6 x 4 switched reluctance motor. Figs. 5-7 show the actual motor phase current waveforms and the on time duration of the power switches under 0, 5, and 14 degrees of advancing for the phase turn on angles, respectively.

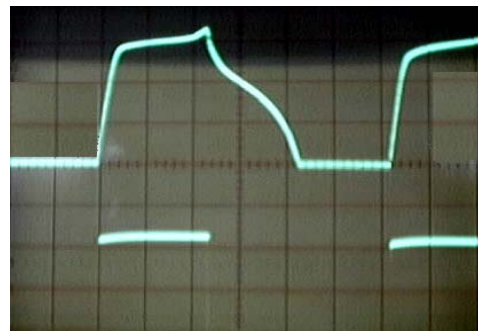
The different parts of current waveforms of Figs. 5-a, 6-a and 7-a may be explained generally with reference to the positions of idealized inductance profile of Fig. 3 using the circuit shown in Fig. 2. The phase winding is connected via switches S1 and S2 to the voltage source  $V_s$  at  $t = 0$  while the phase inductance is low (i.e.  $\theta_1 < \theta < \theta_2$ ), thus permitting current build up at almost linear rate until the phase inductance begins to increase (i.e.  $\theta_2 < \theta < \theta_3$ ). The positive rate of change of phase inductance with time causes the current to fall. From then on the switches are open and the voltage source is connected to the phase winding via the diodes D1 and D2. The current now is flowing through the diodes and also decaying fast. As seen from the current waveforms, more advancement in conduction angle produces larger current in high speed hence, higher torque is obtainable. Phase advancing can also cause the phase commutation to end before the rotor reaches the negative torque region (i.e.  $\theta_4 < \theta < \theta_5$ ). In all of the above figures, one can observe a discharging time which depends on the motor and its drive circuit time constant. The position of the rotor is directly proportional to the motor inductance which constitute the motor time constant. This discharging time can be effectively reduced by introducing a capacitor in the energy return path [10]. In this regard, a new class of resonant discharge circuits has been proposed.



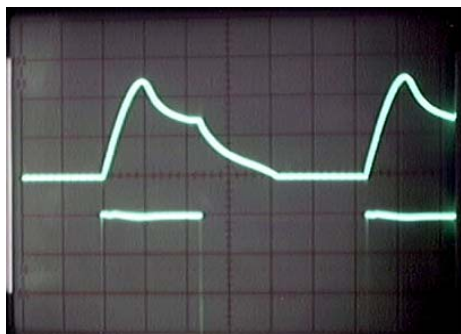
**Fig. 4** (a) Current waveform for 5 Degrees of Advancement (b) Current waveform for 14 Degrees of Advancement



**Fig. 5** (a, upper) Actual current waveforms for zero Deg. of Advancement (b, lower) Power switches turn on time duration (0.5 msec./div, 0.2 A/div)



**Fig. 6** (a, upper) Actual current waveforms for 5 Deg. of Advancement (b, lower) Power switches turn on time duration (0.5 msec./div, 0.2 A/div)



**Fig.7** (a, upper) Actual current waveforms for 14 Deg. of Advancement (b) Power switches turn on time duration (0.5 msec./div, 0.5 A/div)

## 2.2 The First Proposed Drive Circuit

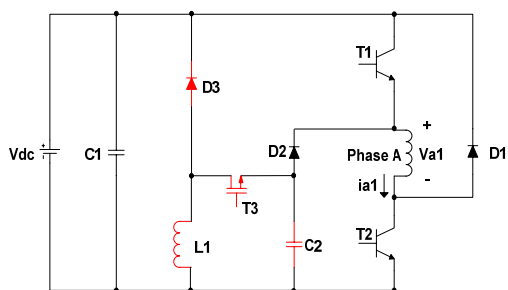
The new drive circuit is shown in Fig. 8. When transistors T1 and T2 are on the current flows through phase A of the motor winding and when the switches are turned off, the excess energy is dumped on capacitor C2 resonantly through diodes D1 and D2. Fig. 9 shows the simulated charge and discharge phase currents for a regular two switch per phase drive circuit as well as the new one.

As shown in Fig. 9-b the discharge period is much smaller for resonant circuit. If this trend continues the excess energy charges the capacitor every time it turned on. Fig. 10 shows the capacitor voltage after several strokes.

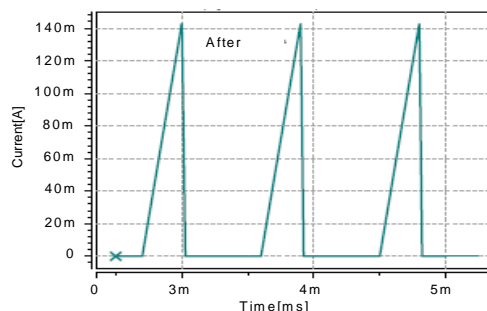
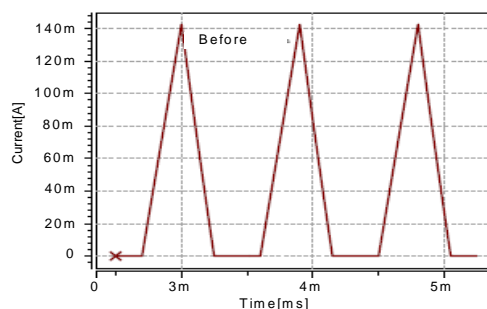
As seen from Fig. 10 capacitor initial voltage is zero and the charges to -160 volts after a few strokes. In order to return this energy back to the main supply another path using a switch connecting the capacitor in series with an inductor and a diode is considered. Fig. 11 shows the simulated motor phase A current as well as the capacitor voltage with the new path.

The simulated as well as the experimental capacitor voltages obtained show a well behaved with an amount or level that is constant stays without rising up voltage in every stroke as shown in Figs. 11-b and 12-b, respectively.

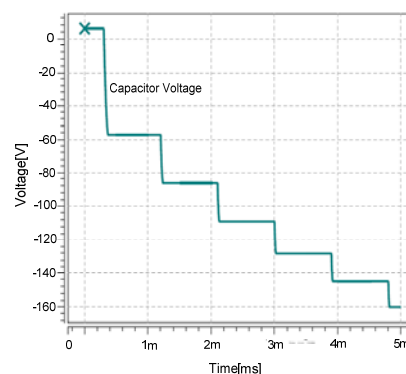
Finally, the shape of input current is shown in Fig. 13. The shape of the current shown in Fig. 13 illustrates a smooth waveform. The speed of motor has increased by about 38% when compared to a two switch per phase topology. The maximum motor speed obtained with no load was about 20000 RPM.



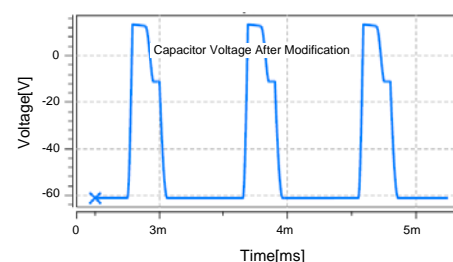
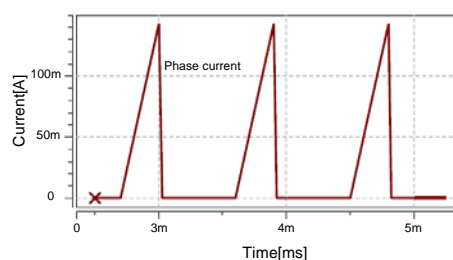
**Fig. 8** The First Drive Circuit Topology



**Fig. 9** The simulated charge and discharge of phase current (a, upper) A Regular two switch per phase topology (b, lower) Two switch per phase with the resonant capacitor



**Fig. 10** The capacitor voltage after several strokes



**Fig. 11** (a) The motor phase A current (b) The capacitor voltage

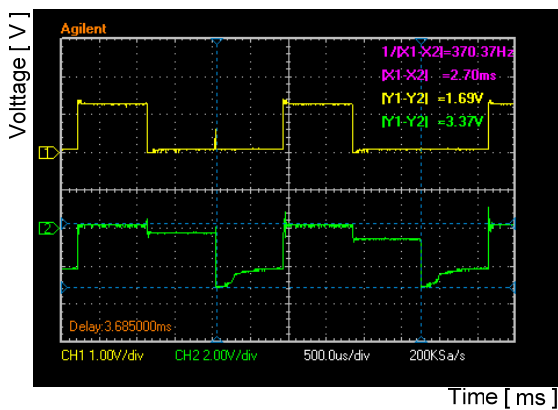


Fig. 12 (a) Transistor gate command (b) The capacitor voltage during turn off

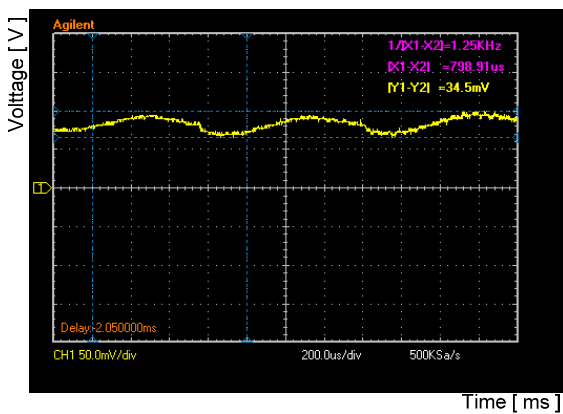


Fig. 13 Shape of current drawn from the voltage source

### 2.3 The Second Proposed Drive Circuit

The second proposed drive circuit is shown in Fig. 14. Suppose the working sequence for the motor is phase1 (L1) First, then phase2 (L2), and finally phase3 (L3), respectively and also the capacitors C1, C2, and C3 are not charged. The excess energy from a phase winding discharges not to the next phase capacitor but to the one after that, in order to have sufficient time to discharge itself via a thyristor. At the beginning, transistor M1 is turned on and current starts to flow into the phase winding L1 through diode D1 while, during this time C1 is short circuited by the diode D1. At the end of this working stroke transistor M1 is turned off and thyristor X1 and transistor M2 are turned on. Now the current flows into the second phase winding L2 through diode D2 and excess energy in the first phase winding charges capacitor C3 above the supply voltage resonantly through X1, C3, and D1 until L1 is fully discharged. Thyristor X1 turns off by itself when current reaches zero. The rising capacitor voltage forces an increasingly rapid decay of the phase current. Now the second phase is turned off and third phase plus thyristor X2 are turned on. At the beginning, the current flows into the third phase winding from charged

capacitor C3 and the source voltage in series then, after the capacitor full discharge, the current flows only from the source voltage through diode D3 into the phase winding. Fig. 15 shows the voltage across capacitor C3, which in this case, the capacitance value is  $0.47 \mu\text{F}$ .

As seen from the above figure, the capacitor voltage rises during the discharge of the phase winding L1 and then stays constant while the second phase (L2) is in progress and finally discharges when the third phase begins its work. The size of capacitors C1, C2, and C3 should be selected in such way that the produced resonant frequency is much higher than the frequency of the switching of the motor phases [9]. Fig. 16 shows the capacitor voltage waveform for a bigger capacitance value, in this case  $3.4 \mu\text{F}$ .

Since the resonant frequency has gone down the flat part of the voltage wave form does not exist as before. The phase current that was flowing through transistor M1 commutates to the thyristor X1 and begins to charge the capacitor resonantly and then at the beginning of the other strokes discharges to phase winding. Fig. 17 shows the capacitor current wave form for the same capacitance value in Fig. 16.

Since the current in a capacitor is proportional to the derivative of the voltage across it then, there are positive and negative jumps at the beginning of capacitor voltage rise and fall periods. Fig. 18 shows the current waveform for the first phase winding L1 and capacitance value of  $0.47 \mu\text{F}$  for the C3.

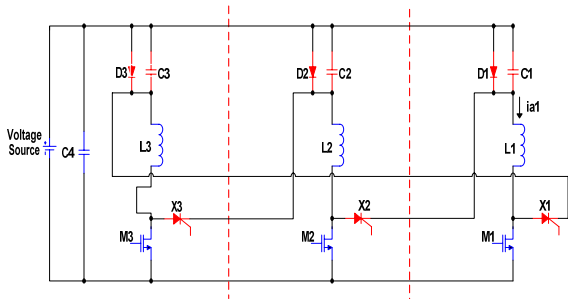
The current waveform has different distinct parts. First, there is a fast rise due to current produced by the charged capacitor and the source in series at the beginning of the phase turn on period. In the second part, there is another rise due to the source voltage only. In the third part, the current begins to drop due to the stator and rotor overlapping. Finally in the last part, a fast decay due to the charging of the capacitor resonantly during the turn off period is evident.

In Fig. 19 the same motor phase current, using a two switch per phase configuration for the drive circuit. In Fig. 19, again a current rise due to the phase turn on and then decay because of over lapping between stator and rotor poles and then a second decay due to the phase turn off. Comparing Figs. 18 and 19, one finds faster rise and fall times during turn on and turn off periods for the current waveform in Fig. 18. The speed of motor has increased by about 34% when compared to a two switch per phase topology.

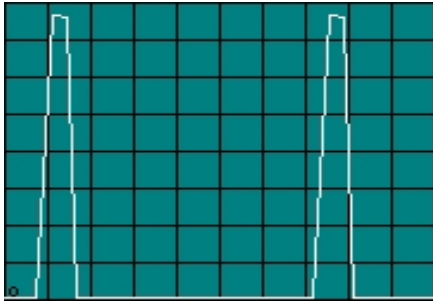
The driver circuit was also simulated. Fig. 20 shows the simulated charge and discharge phase currents for a regular single switch per phase drive circuit with H-spice simulation software.

Simulation results obtained from H-spice software are truly in agreement with actual outcomes. The maximum motor speed obtained with no load was about 19000 RPM.

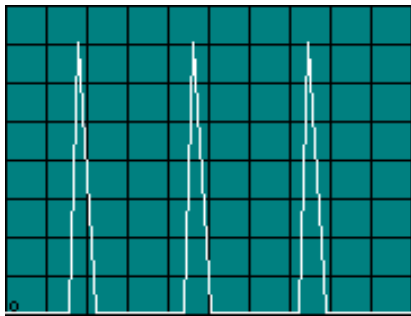




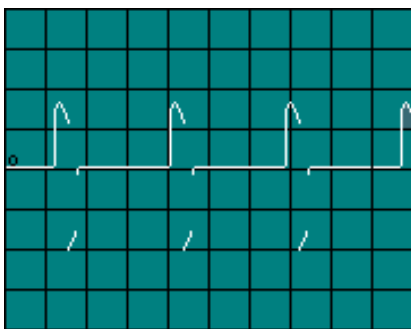
**Fig. 14** The Second Drive Circuit Topology



**Fig. 15** The voltage across capacitor C3 (0.5 msec./div, 20 V/div)



**Fig. 16** The capacitor voltage waveform for a 3.4  $\mu$ F Capacitor (1 msec./div, 20 V/div)

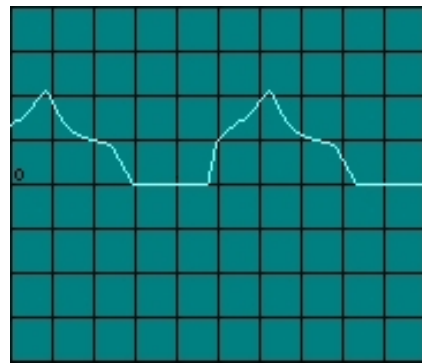


**Fig. 17** Capacitor current waveform for a 3.4  $\mu$ F Capacitor (1 msec./div, 0.5 A/div)

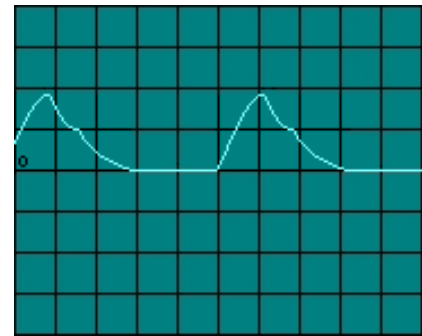
### 2.4 The Third Proposed Drive Circuit

The new resonant bifilar drive circuit is shown in Fig. 21. In the new Bifilar winding converter arrangement the number of switches and diodes per phase are the same as a regular bifilar circuit but with an added capacitor in series with the freewheeling diode in each phase. Current flows into the primary winding

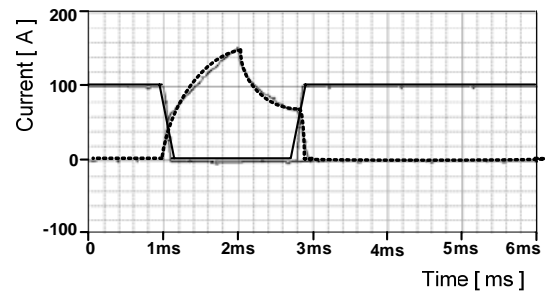
when the switching transistor is on. By turning the transistor off, the primary current falls to zero. This establishes a corresponding current in the secondary winding so as to maintain constant flux linkages. This secondary current flows through a diode, a capacitor and returns the excess energy to the power supply resonantly. Utilizing the series capacitor in the bifilar winding causes faster rate of energy discharge due to the fast decaying resonant current. A lossless snubber, consists of an inductor, a capacitor and a diode are also used to prevent high voltage spikes on the switching power transistors. When the motor phase is energized, current begins to flow through the motor main winding. Figs. 3-a and 3-b show the main phase winding current in the new bifilar resonant topology with lossless snubber and a regular bifilar topology, respectively.



**Fig. 18** The current waveform for phase winding L1 (0.5 msec./div, 0.5 A/div)



**Fig. 19** The current waveform for phase winding L1 (0.5 msec./div, 0.5 A/div)



**Fig. 20** Dashed line: Phase current multiplied by 10 in Amperes. Solid line: Capacitor voltage divided by 10 in Volts

There are three distinct regions in the main phase current namely, rising current due to low phase inductance, declining current due to overlapping of the rotor and stator poles, and finally a fast decrease due to opening the main switch. There are no major differences in the waveforms of Figs. 22 and 23 as expected, since the resonant circuit is not active in this mode of motor operation. The small changes in currents in Figs. 22 and 23 are due to the operation of lossless snubber. In the regular bifilar topology the current abruptly goes to zero where in the new circuit is not the case. The motor speed has also gone up in the new topology because of less breaking effect caused by faster current discharge [10].

In Fig. 24 the envelope of the discharged current is shown where as Fig. 25 the discharge current in a regular bifilar winding is demonstrated.

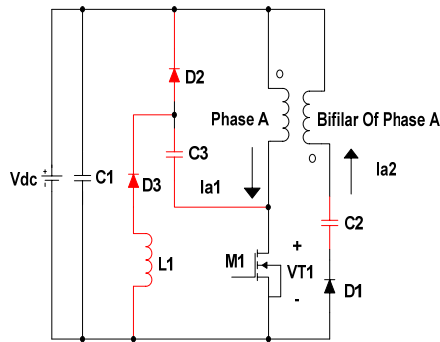


Fig. 21 The Third Drive Circuit Topology

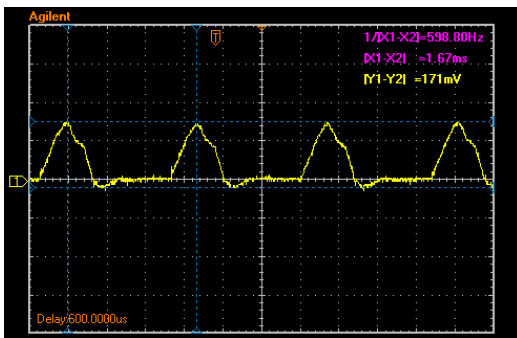


Fig. 22 Current in one phase (New Circuit). (500 μsec/div, 100 mV/div)

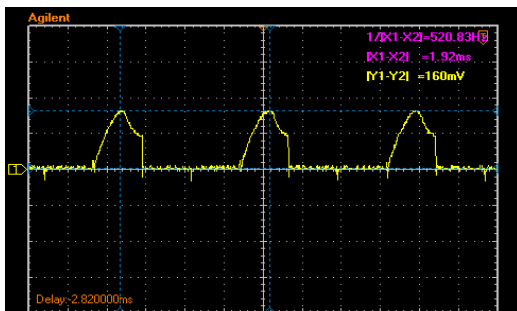


Fig. 23 Current in one phase (regular bifilar). (500 μsec/div, 100 mV/div)

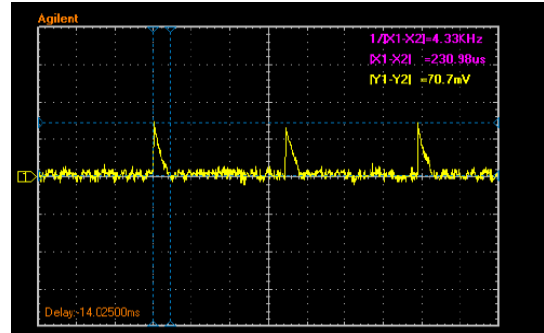


Fig. 24 Discharged current (with snubber). (500 μsec/div, 50 mA/div)

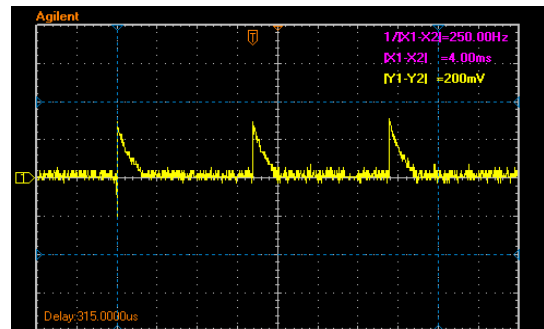


Fig. 25 Discharged current (without snubber). (500 μsec/div, 50 mA/div)

Comparing Fig. 24 with 25 shows a big change in decay time. The driver with resonant circuit shows much faster decay time than the regular bifilar configuration. This is to be expected since the discharge is being carried out by a resonant circuit with a resonant frequency of  $\omega = \frac{1}{\sqrt{LC}}$ , while in a regular bifilar the

discharge current circuit is just a first order circuit with a time constant of  $L/R$ . One of the problems is high voltage spikes during transistor switching which puts a lot of stress on the transistors. In order to reduce the  $L di/dt$  voltages on the power transistors a lossless snubber employed for each phase.

Figs. 26 and 27 show the actual drain to source voltages of the main switching transistor for the resonant circuit as well as the circuit without the lossless snubber. The drain to source voltage on the transistor with the snubber is about 60 volts, in spite of without snubber that is at least 250 volts.

The complete driver circuit was also simulated. Figs. 28 and 29 show the motor phase current using the new drive circuit and also a regular bifilar configuration, respectively. The speed of motor has increased by about 35% when compared to a two switch per phase topology. The maximum motor speed obtained with no load was about 20000 RPM.

Comparing Figs. 28 and 29, one finds faster fall times during turn off periods for the current waveform in Fig. 9-b.

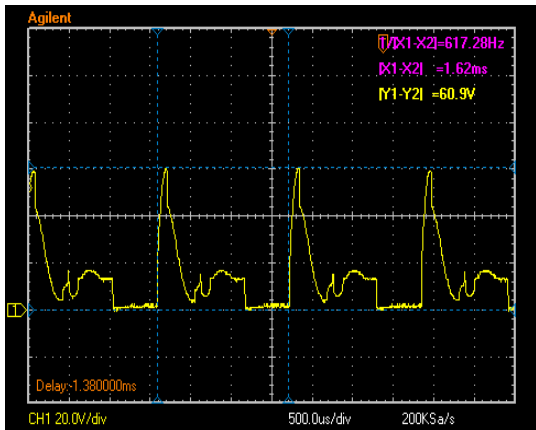


Fig. 26 Transistor VDS with snubber (500  $\mu$ sec./div, 20 V/div)

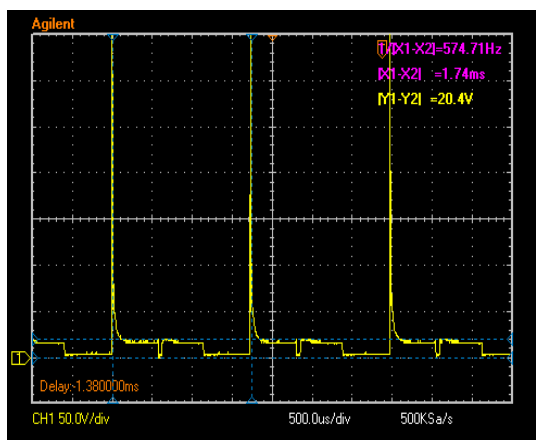


Fig. 27 Transistor VDS without snubber (500  $\mu$ sec./div, 50 V/div)

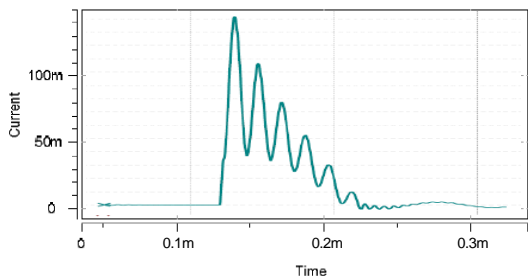


Fig. 28 The discharged current waveform (new circuit)

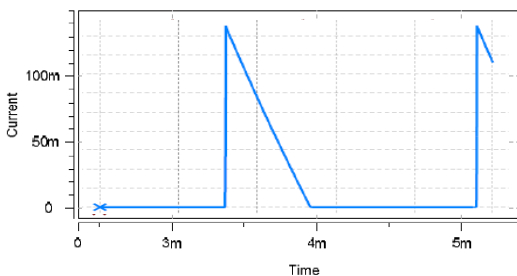


Fig. 29 The discharged current waveform (regular bifilar)

### 3 Conclusion

A new class of drive circuit using a resonant discharge has developed and demonstrated a new class of converter circuit for switched reluctance motor. The new drive circuits use a capacitor in the phase discharge path in order to reduce the discharging time. These drive circuits have been tested successfully on a 25 W, three-phase 6 by 4 motor and a detailed explanation and demonstration of the converter circuit have been presented. The motor with the new resonant drive circuit has almost 38% and 35% increase in speed when compared to the same motor but with a two switch per phase and a regular bifilar drive circuits, respectively. The main reason for the motor speed is due to the faster rate of fall for the phase current, which permits the motor to operate at higher speeds. The maximum motor speed obtained for this class of drive circuits was about 20000 RPM at the rated current without out any loads, while, using a standard two switch per phase with the same conditions the motor produced a speed of about 14000 RPM.

### Acknowledgment

This work was supported in part by a grant from Shahid Beheshti Power Electronic Lab.

### References

- [1] Asgar M., Afjei E., A. Siadatan and Zakerolhosseini A., "A New Modified Asymmetric Bridge Drive Circuit for SRM," *IEEE European Conference on Circuit Theory and Design*, pp. 539 - 542, Antalya, Aug. 2009.
- [2] Asgar M., Afjei E. and Siadatan A., "A New Class of Resonant Discharge Drive Topology For Switched Reluctance Motor," *IEEE Power Electronics and Applications, EPE '09*, pp. 1-9, Spain, Sep. 2009.
- [3] Alaei M. M., Afjei E. and Ataei S., "A New Resonant Driver for SRM," *IEEE Electrical Engineering, ICEE '07*, pp. 1-3, Lahore, Apr. 2007.
- [4] Krishnan R., *Switched Reluctance Motor Drive: Modeling, simulation, Analysis, Design and application*, Magna physics publishing, 2001.
- [5] Mir S., "Classification of SRM Converter Topologies for Automotive Application," *SAE Tech. No. 000-01-0133*, Mar. 2000.
- [6] Gallegos-Lopez G., Walters J. and Jahekarta K., "SRM control strategies for automotive applications," *SAE Technical*, No.2001-01-0995, Mar. 2001.
- [7] Bass J. T., Ehsani M. and Miller T. J., "Development of a Unipolar Converter for Variable Reluctance Motor Drives," *IEEE Transactions*, Vol. IA-23, pp. 545-553, 1987.
- [8] Afjei E., "A new resonant converter circuit for reluctance motor," *International journal of engineering*, Vol.12, pp. 69-80, May 1999.



- [9] Krishnan R. and Materu P. N., "Design of a Single-Switch-Per-Phase Converter for Switched Reluctance Motor Drives," *IEEE Transaction on Industrial Electronics*, Vol. 37, No. 6, pp. 469-476, Dec. 1990.
- [10] Bazzaz P., Afjei E. and Toliyat H. A., "A New Drive Circuit for Switched Reluctance Motor," *IEEE International Electric Machines and Drives Conference*, pp. 71-73, May 2005.
- [11] Afjei E., Asgar M. and Ataei S., "A New modified bifilar Drive Circuit for Switched Reluctance Motor," *IEEE power Conf.*, pp. 1-4, India, Oct. 2008.



**Majid Asgar** received the B.S. degree in electrical engineering from the Shahid Rajaei University, Tehran, Iran, in 1993, and M.S. degree in electrical engineering from the Shahid Beheshti University, Tehran, Iran, in 2008. He is currently a Student of Ph.D. in Electrical Engineering, Shahid Beheshti University, Tehran, Iran. His research interests are in the areas of power electronics and switched reluctance motor drives.



**Ebrahim S. Afjei** received the B.S. and M.S. degrees in electrical engineering from the University of Texas in 1984, 1986 respectively, and the Ph.D. degree from New Mexico State University, in 1991. He is currently a Professor in the Department of Electrical Engineering, Shahid Beheshti University, Tehran, Iran. His research interests are in the areas of switched reluctance motor drives, Numerical analysis and power electronics.