

Fuzzy Control of Fuel Cell Distributed Generation Systems

A. Hajizadeh* and M. Aliakbar-Golkar**

Abstract: The operation of Fuel Cell Distributed Generation (FCDG) systems in distribution systems is introduced by modeling, controller design, and simulation study of a Solid Oxide Fuel Cell (SOFC) distributed generation (DG) system. The physical model of the fuel cell stack and dynamic models of power conditioning units are described. Then, suitable control architecture based on fuzzy logic control for the overall system is presented in order to active power control and power quality improvement. A MATLAB/Simulink simulation model is developed for the SOFC DG system by combining the individual component models and the controllers designed for the power conditioning units. Simulation results are given to show the overall system performance including active power control and voltage regulation capability of the distribution system.

Keywords: Distributed Generation, Fuel Cell, Fuzzy Control, Power Quality, Voltage Regulation.

1 Introduction

Distributed Generation (DG) systems, powered by microsources such as fuel cells, photovoltaic cells, and microturbines, have been gaining popularity among the industry and utilities due to their higher operating efficiencies, improved reliabilities, and lower emission levels. The introduction of DG to the distribution system has a significant impact on the flow of power and voltage conditions at the customers and utility equipment [1, 2]. These impacts might be positive or negative depending on the distribution system operating characteristics and the DG characteristics. Positive impacts include, voltage support and improved power quality, diversification of power sources, Reduction in transmission and distribution losses, transmission and distribution capacity release and improved reliability. Among the distributed generators, fuel cells are attractive because they are modular, efficient, and environmentally friendly [3]. Fuel Cell DG (FCDG) systems can be strategically placed at any site in a power system (normally at the distribution level) for grid reinforcement, thereby deferring or eliminating the need for system upgrades and improving system integrity, reliability, and efficiency. Therefore, proper controllers need to be designed for a FCDG system to make its performance characteristics as desired [4, 5].

Stevandic J. Jiang [6] develop a standalone, reduced-order, dynamic model of fuel cell power plant connected to a distribution grid via dc/ac converter. Sedghisigarchi and Feliachi [7] proposed a model includes the electrochemical and thermal aspects of chemical reactions inside the fuel-cell stack (i.e., temperature and chemical species dynamics are considered) but the dynamics model of DC/DC and DC/AC Converters are not considered. Jurado and Valverde [8] presented the design of a new fuzzy logic regulator for a three-phase inverter using the strategy of inverter flux vector control method. But in this paper the control of fuel cell power plant and the active power control have not been considered and the focus is on the design of DC/AC converter controller. In [9] a novel hierarchical control architecture for a hybrid distributed generation system that consists of dynamic models of a battery bank, a solid oxide fuel cell and power electronic converters has been presented but the voltage regulation capability and reactive power control of FCDG have not been addressed. So it is important to develop a proper modeling of FCDG system and design suitable control strategies for all components to attain good performances such as optimal operation of fuel cell stack and power quality improvement. Also by authors in [10], a control strategy has been developed for FCDG system to power quality improvement and active power control in distribution systems. But the dynamic model of fuel cell system and fuel flow controller has not been presented. Hence, in this paper the fuzzy control structure has been developed for a FCDG system with active power management and reactive power control capability.

Iranian Journal of Electrical & Electronic Engineering, 2007.

* Amin Hajizadeh is the Ph.D. student of the Electrical Engineering Department, K.N. Toosi University of Technology, Tehran, Iran.

E-mail: aminhajizadeh@ieec.org

** Masoud Aliakbar-Golkar is an Associate Professor of the Electrical Engineering Department, K.N. Toosi University of Technology, Tehran, Iran.

E-mail: golkar@eetd.kntu.ac.ir

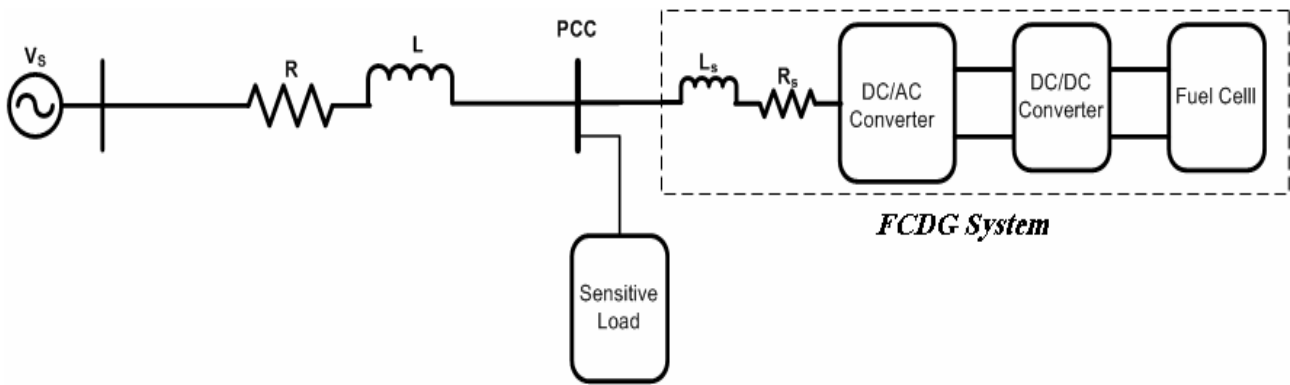

Fig. 1 Fuel Cell Distributed Generation System Structure.

The fuel cell power plant is interfaced with the utility grid via boost dc/dc converters and a three-phase pulse width modulation (PWM) inverter. A validated SOFC dynamic model, reported in [11], is used in this paper. The models for the boost dc/dc converter and the three-phase inverter together are also addressed. The controller design methodologies for the dc/dc and dc/ac converters are also presented for the proposed fuel cell DG system. Based on the individual component models developed and the controllers designed, a simulation model of the SOFC DG system has been built in MATLAB/Simulink environment. Simulation results show that the active power control and voltage regulation in distribution systems by FCDG system.

2 Dynamic Modeling of Fuel Cell Distributed Generation Systems

The dynamic modeling of a Fuel Cell Distributed Generation (FCDG) system is an important issue that needs to be carefully addressed. To study the performance characteristics of FCDG systems, accurate models of fuel cells are needed. Moreover, models for the interfacing power electronic circuits in a FCDG system are also needed to design controllers for the overall system to improve its performance and to meet certain operation requirements [12]. To meet the system operational requirements, a FCDG system needs to be interfaced through a set of power electronic devices. Fig. 1 shows the block diagram of the FCDG system proposed in this paper. The electric components of the FCDG system used in this paper comprise DC/DC and DC/AC converters, while the electrochemical component is a Solid Oxide Fuel Cell system (SOFC). The mathematical models describing the dynamic behavior of each of these components are given below.

2.1 Fuel Cell Model

Fuel cells are static energy conversion devices that convert the chemical energy of fuel directly into electrical energy. They show great promise to be an important DG source of the future due to their many advantages, such as high efficiency, zero or low emission (of pollutant gases), and flexible modular

structure. The model of SOFC power plant used in this study is based on the dynamic SOFC stack model developed and validated in [11]. The performance of FCs is affected by several operating variables, as discussed in the following. One of important operating variable is the reactant utilization, U_f , referring to the fraction of the total fuel (or oxidant) introduced into a FC that reacts electrochemically:

$$U_f = \frac{q_{H_2}^{in} - q_{H_2}^{out}}{q_{H_2}^{in}} = \frac{q_{H_2}^r}{q_{H_2}^{in}} \quad (1)$$

where q_{H_2} is the hydrogen molar flow. High utilizations are considered desirable (particularly in smaller systems) because they minimize the required fuel and oxidant flow, for a minimum fuel cost and compressor load and size. However, utilizations that are pushed too high result in significant voltage drops. The SOFC consists of hundreds of cells connected in series and parallel. Fuel and air are passed through the cells. By regulating the level, the amount of fuel fed into the fuel cell stacks is adjusted, and the output real power of the fuel cell system is controlled. The Nernst's equation and Ohm's law determine the average voltage magnitude of the fuel cell stack [13]. The following equations model the voltage of the fuel cell stack:

$$V_{fc} = N_0 (E_0 + \frac{RT}{2F} (\ln(\frac{P_{H_2} P_{O_2}^{0.5}}{P_{H_2O}})) - rI_{f0}) \quad (2)$$

where:

N_0 is the number of cells connected in series;

E_0 is voltage associated with the reaction free energy;

R is the universal gas constant;

T is the temperature;

I_{f0} is the current of the fuel cell stack;

F is the Faraday's constant.

P_{H_2} , P_{H_2O} , P_{O_2} are determined by the following differential equations:

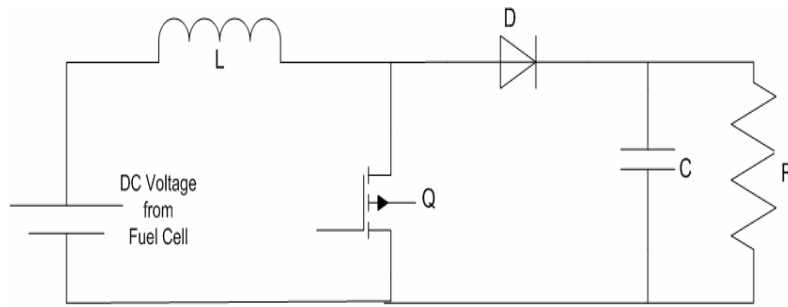

Fig. 2 DC/DC Converter Model.

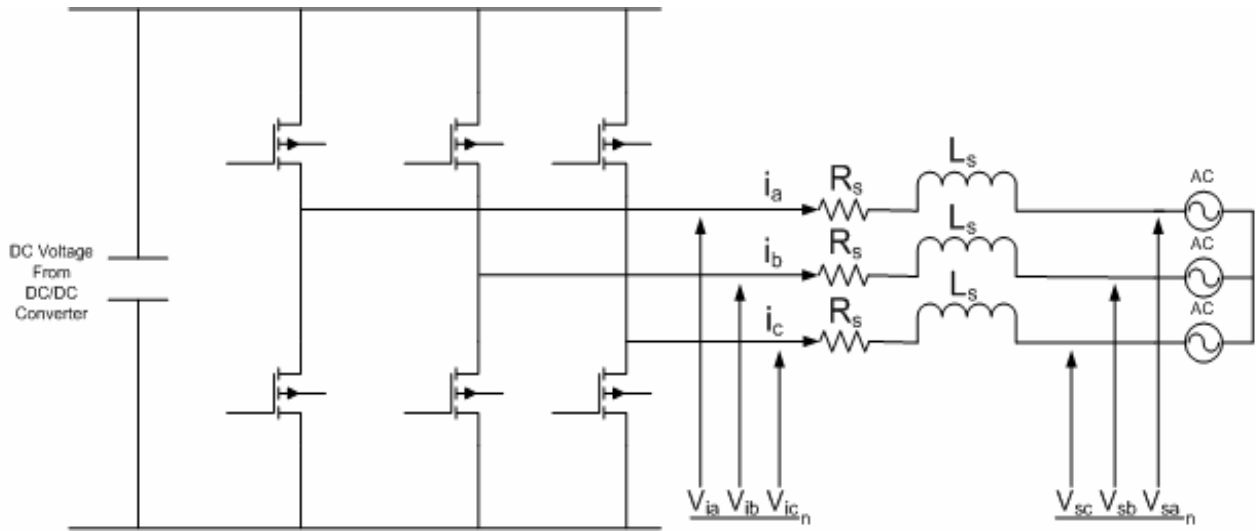

Fig. 3 Three-phase dc/ac voltage source inverter.

$$\begin{aligned} \dot{P}_{H_2} &= -\frac{1}{t_{H_2}}(P_{H_2} + \frac{1}{K_{H_2}}(q_{H_2}^{in} - 2K_r I_{fc})) \\ \dot{P}_{H_2O} &= -\frac{1}{t_{H_2O}}(P_{H_2O} + \frac{2}{K_{H_2O}}K_r I_{fc}) \\ \dot{P}_{O_2} &= -\frac{1}{t_{O_2}}(P_{O_2} + \frac{1}{K_{O_2}}(q_{O_2}^{in} - K_r I_{fc})) \end{aligned} \quad (3)$$

where, $q_{H_2}^{in}$ and $q_{O_2}^{in}$ are the molar flow of hydrogen and oxygen and where the K_r constant is defined by the relation between the rate of reactant hydrogen and the fuel cell current:

$$q_{H_2}^r = \frac{N_0 I}{2F} = 2K_r I \quad (4)$$

2.2 DC/DC Converter Model

To connect a fuel cell to an external power system, it is necessary to boost the fuel cell voltage or to increase the number of cells. The role of the DC/DC booster converter is to increase the fuel cell voltage, to control the fuel cell power, and to regulate the voltage. Fig. 2

shows the DC/DC converter model. This boost converter is described by the following two non-linear state space averaged equations [14]:

$$\begin{aligned} \rho X_1 &= \frac{(1-d)}{L} X_2 + \frac{d}{L} U \\ \rho X_2 &= \frac{-(1-d)}{C} X_1 - \frac{X_2}{RC} \end{aligned} \quad (5)$$

where “d” is the on time of the switching device, “U” is the input voltage, “X₁” is the inductor current and “X₂” is the output voltage.

2.3 DC/AC Converter Model

A dynamic model of voltage source inverter has been developed. A three-phase equivalent circuit of DC/AC converter is shown in Fig. 3. To reduce these harmonics, filters are connected between the converter and the grid. A first-order filter, represented by the L_s and the R_s in Fig. 3, is used. In Fig. 3, v_{ia} , v_{ib} , v_{ic} are the three-phase AC voltage outputs of the inverter, and i_a , i_b , i_c are the three-phase AC current outputs of the inverter. The bus voltages of the grid are v_{sa} , v_{sb} , v_{sc} . The dynamic model of three-phase VSC is represented in [15].

$$\frac{di_k}{dt} = -\frac{R_s}{L_s}i_k + \frac{1}{L_s}(v_{ik} - v_{sk}) \quad (6)$$

where $k = \{a, b, c\}$.

To develop the dynamic model, the state equations (6) are transformed to the system synchronous reference frame as:

$$\begin{aligned} \frac{di_q}{dt} &= -\frac{R_s \omega_s}{L_s}i_q - \omega_s i_d \\ &\quad + \frac{\omega_s}{L_s}m \sin(\delta + \theta_s)V_{dc} \\ &\quad - \frac{\omega_s}{L_s}\sin(\theta_s)V_s \\ \frac{di_d}{dt} &= -\frac{R_s \omega_s}{L_s}i_d + \omega_s i_q \\ &\quad + \frac{\omega_s}{L_s}m \cos(\delta + \theta_s)V_{dc} \\ &\quad - \frac{\omega_s}{L_s}\cos(\theta_s)V_s \end{aligned} \quad (7)$$

3 Control Strategy for FCDG system

There is a high demand for utility DG installations due to their advantages of deferment or upgrading the distribution infrastructure. Most DG units are connected to the distribution system through a shunt nonlinear link such as a Voltage Source Inverter (VSI) or a Current Source Inverter (CSI). The main function of the shunt connection is to control the amount of active power drawn from the DG source. This link can emulate

DSTATCOM devices by controlling the reactive power, as well as the active power. Hence, it is necessary to design a control structure to manage active power and reactive power simultaneously. Moreover, the control strategy must be designed to mitigate different power quality problems. Also, the suitable control is presented to regulate the input fuel flow in order to meet a desirable output active power demand and to prevent transient conditions in fuel cell stack. The control structure that has been proposed in this paper has been shown in Fig. 4. As shown, this structure has been composed of different local units. By using of distributed fuzzy logic controllers in this structure makes that it has adaptive properties in distribution systems [10]. Fuzzy control is a practical alternative for a variety of challenging control applications since it provides a convenient method for constructing nonlinear controllers via the use of heuristic information. A fuzzy logic controller used in this research consists of the rule base, fuzzification, inference engine, and defuzzification. The rule base collects the control rules which describe experts' knowledge and experience in the fuzzy set. In the fuzzification process, the numerical inputs are converted into linguistic fuzzy values. Then, from the fuzzy values and the already established rule base, linguistic control values are generated in the inference engine. Because these linguistic inference results cannot be used in the actuator directly, they should be converted into numerical output again in the defuzzification process. MAX-MIN composition and the center of gravity method are used in the inference engine and defuzzification of this fuzzy logic, respectively.

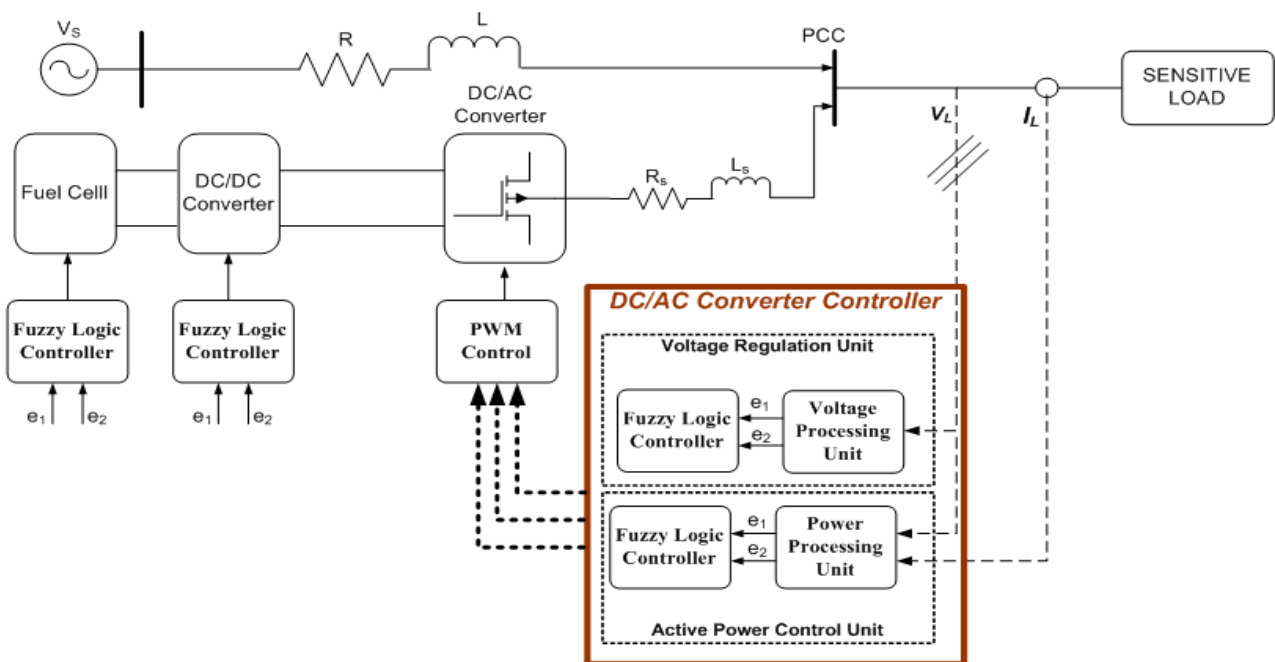

Fig. 4 Control Structure of Fuel Cell Distributed Generation System.

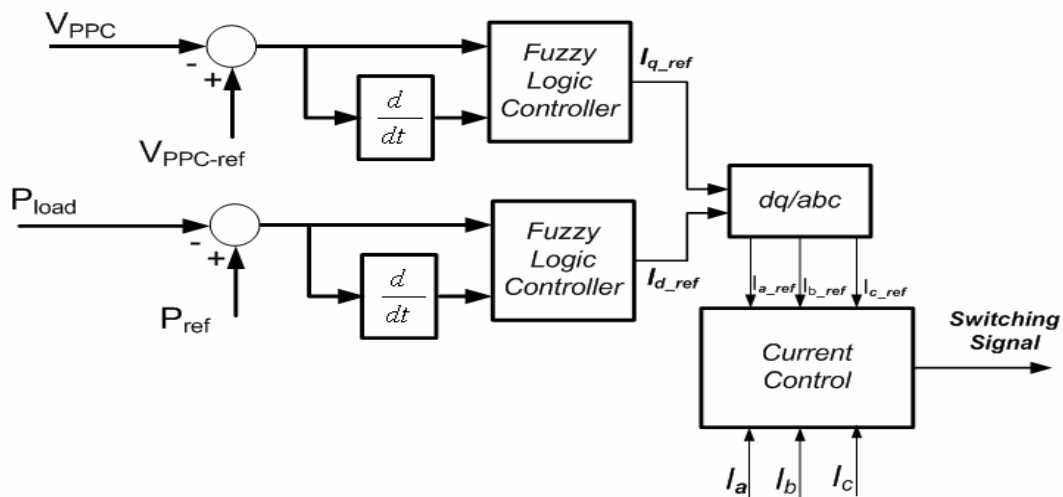

Fig. 5 DC/AC Converter Controller.

3.1 DC/AC Converter Controller

Power quality has attracted considerable attention from both utilities and users due to the use of many types of sensitive electronic equipment, which can be affected by harmonics, voltage sag, voltage swell, and momentary interruptions [16]. These disturbances cause problems, such as overheating, motor failures, inaccurate metering, and misoperation of protective equipment. Voltage disturbance is the common power quality problem in industrial distribution systems. The voltage disturbance mainly encompasses voltage sags, voltage swells, voltage harmonics, and voltage unbalance. The voltage disturbance notoriously affects voltage-sensitive equipment that eventually leads to malfunction. Voltage sag is one of the most severe power quality problems because of its adverse financial impact on customers [17]. The DC/AC Converter Controller, as shown in Fig.5, has been formed of two parts, voltage regulation unit and active power control unit.

3.1.1 Voltage Regulation Unit

To achieve the voltage regulation task, the current i_{q-ref} is assigned to the output of the FLC. The actual inputs to the fuzzy system are scaled versions of both the rms voltage error and its derivative. Seven uniformly distributed triangle membership functions are used for the fuzzification of the inputs [10]. Each of the FLC input signals and output signals are fuzzy variables and are assigned seven linguistic variables, namely, NB, NM, NS, Z, PS, PM, and PB, which stand for negative big, negative medium, negative small, zero, positive small, positive medium and, positive big, respectively. The rule base is designed so that the actual rms voltage can reach its command value as quickly as possible within the shunt compensator limitation without overshoot. This leads to the rules as listed in Table 1.

3.1.2 Active Power Control

A fuzzy logic controller has been designed to control active power drawn from load. The actual inputs to the

fuzzy system are scaled versions of both the active power error and its derivative and the current i_{d-ref} is assigned to the output of the FLC [10]. Seven uniformly distributed triangle membership functions are used for the fuzzification of the inputs. Each of the FLC input signals and output signals are fuzzy variables and are assigned seven linguistic variables, namely, NB, NM, NS, Z, PS, PM, and PB, which stand for negative big, negative medium, negative small, zero, positive small, positive medium and, positive big, respectively. The rule base of active power controller has been listed in Table 2.

Table 1 Fuzzy Rule Base for Voltage Regulation.

Δi_{q-ref}	e_2							
	NB	NM	NS	Z	PS	PM	PB	
e_1	NB	PB	PB	PB	PM	PM	PM	PS
	NM	PB	PB	PM	PM	PM	Z	NB
	NS	PB	PM	PM	PM	PS	NS	NB
	Z	PB	PM	PS	Z	NS	NM	NB
	PS	PB	PS	NS	NM	NM	NM	NB
	PM	PB	Z	NM	NM	NM	NB	NB
	PB	NS	NM	NM	NM	NB	NB	NB

Table 2 Fuzzy Rule Base for Active Power Control.

Δi_{d-ref}	e_2							
	NB	NM	NS	Z	PS	PM	PB	
e_1	NB	NB	NB	NB	NB	NM	NS	Z
	NM	NB	NB	NB	NM	NS	Z	PS
	NS	NB	NM	NS	NS	Z	PS	PM
	Z	NB	NM	NS	Z	PS	PM	PB
	PS	NM	NS	Z	PS	PM	PM	PB
	PM	NS	Z	PS	PM	PB	PB	PB
	PB	Z	PS	PM	PB	PB	PB	PB

3.2 DC/DC Converter Controller

The unregulated output voltage of the FC is fed to the dc/dc boost converter. Being unregulated it has to be adjusted to a constant average value (regulated dc voltage) by adjusting the duty ratio to the required value. The voltage is boosted depending upon the duty ratio. The duty ratio of the boost converter is adjusted with the help of a fuzzy logic controller (FLC). The duty ratio is set at a particular value for the converter to provide desired average value of voltage at the output, and any fluctuation in the FC voltage due to change in fuel flow, in the load or in the characters of FC due to the chemistry involved takes the output voltage away from the desired average value of the voltage. The FLC changes the duty ratio appropriately to get the desired average value. The boost converter responds fast to the changes in the duty ratio. The duty ratio of the converter is changed by changing the pulses fed to the switch in the dc/dc converter circuit by the PWM generator. The fuel flow also needs to be adjusted, which takes effect gradually and controls the output voltage. Thus, both the strategies have to be combined for the efficient control of voltage of the FC. This paper concentrates only on the boost converter control strategy. The response time of the dc/dc converter is very short compared to that of the reformer of the FC, which alters the fuel flow. Thus, for the fast system response, initially the converter is controlled for load variations and the average voltage is adjusted in the transitional period by the boost converter. The output of the dc/dc converter is the boosted voltage that is fed to the load or to the next stage of filter to eventually pass on to the inverter stage. This boosted voltage is compared with a reference dc voltage to generate an error signal. The change in error is calculated. The error and the change in error are fed as inputs to the Fuzzy Logic Controller (FLC) [10]. The FLC generates control signal based upon the inputs and rule base. The control signal is fed to the PWM generator. The PWM generator based upon the control signal adjusts the pulses of the switch of the boost converter. The boost converter generates output voltage based upon the duty ratio provided by the PWM generator. Table 3 shows the rule base of DC/DC converter controller.

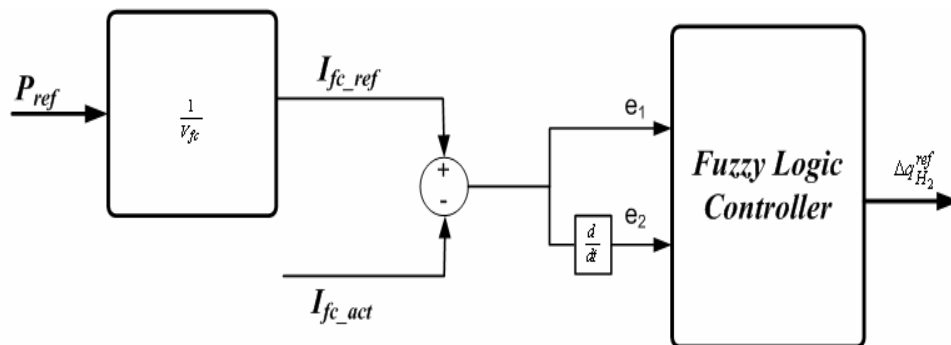

Fig. 6 Control structure for hydrogen molar flow of fuel cell system.

Table 3 Fuzzy Rule Base for Duty Ratio Control of DC/DC Converter.

Δd		e_2						
		NB	NM	NS	Z	PS	PM	PB
e_1	NB	NB	NB	NB	NB	NM	NS	Z
	NM	NB	NB	NB	NM	NS	Z	PS
	NS	NB	NM	NS	NS	Z	PS	PM
	Z	NB	NM	NS	Z	PS	PM	PB
	PS	NM	NS	Z	PS	PM	PM	PB
	PM	NS	Z	PS	PM	PB	PB	PB
	PB	Z	PS	PM	PB	PB	PB	PB

3.3 Fuel Cell Controller

In order to operate the fuel cell stack at an optimal fuel utilization point (approximately 85%) [18], the control algorithm should observe the following operational constraints of the fuel cell system:

Underused fuel: If the fuel utilization drops below a certain limit, the cell voltage will rise rapidly.

Overused fuel: If the fuel utilization increases beyond a certain value, the cells may suffer from fuel starvation and be permanently damaged.

Under voltage: The fuel cell characteristic poses a lower cell voltage limit of approximately 0.5 V, beyond which the cell voltage decreases very steeply with increasing current. To meet the aforementioned usage requirements, the basic target of the fuel cell controller is to maintain optimal hydrogen utilization, $U_{f, opt}$, around 85%. Equation (4) shows that the reacting fuel quantity, $q_{H_2}^r$, is directly proportional to the output current, I , the factor K_r being a cell constant. Hence, the desired utilization is translated to corresponding output current demand:

$$q_{H_2}^{in} = \frac{2K_r}{U_{f,opt}} I_{demand} \Rightarrow I_{demand} = \frac{U_{f,opt}}{2K_r} q_{H_2}^{in} \quad (8)$$

A typical range of U_f is 80-90% ([18]), which ensures that the operational limits mentioned above are observed. The corresponding limitation for the demand current is then:

$$\frac{0.8q_{H_2}^{in}}{2K_r} = I_{fc_min} \leq I_{fc_ref} \leq I_{fc_max} = \frac{0.9q_{H_2}^{in}}{2K_r} \quad (9)$$

Under these conditions, the cell output power is directly related to its fuel consumption at the selected optimum operating point of the V-I characteristic. Operating the fuel cell at different output power levels requires suitable variation of its input fuel flow rate, to be realized by the overall control system of the fuel cell. The power demand requirement of the fuel cell is translated into a current demand input by dividing with the stack output voltage:

$$I_{demand} = \frac{P_{demand}}{V_{fc}} \quad (10)$$

To overcome the transient conditions in fuel cell, a fuzzy logic controller has been designed. The actual inputs to the fuzzy system are scaled versions of both the fuel cell current error and its derivative and the hydrogen molar flow q_{H_2-ref} is assigned to the output of the FLC. Seven uniformly distributed triangle membership functions are used for the fuzzification of the inputs. This leads to the rules as listed in Table 4. Each of the FLC input signals and output signals are fuzzy variables and are assigned three linguistic variables, namely, S, M, L, N, Z and P, which stand for small, medium, large, negative, zero, positive respectively. However, for preventing transient condition on output voltage of fuel cell, the rule based of FLC must be designed correctly. The control structure for fuel cell system has been shown in Fig. 6.

Table 4 Fuzzy Rule Base for the hydrogen molar flow of the fuel cell.

Δq_{H_2-ref}		e_2		
		N	Z	P
e_1	S	NL	Z	PS
	M	NS	Z	PS
	L	NS	PS	PL

4 Simulation Results

The performance of the proposed structure is assessed by a computer simulation that uses MATLAB Software. The parameters of the system under study are given in Table 5. The study case is dedicated to test the dynamic performance of the proposed structure. A voltage sag will be used to examine the dynamical performance of

the algorithm. It is assumed that the three phase voltages were balanced until a disturbance has occurred in the system at 0.25 second. The disturbance causes a voltage sag in the three voltages, as shown in Fig. 7. Before the disturbance, the system was balanced and, therefore, the negative component vanishes. The voltage at the PCC is equal to 1.0 pu during normal operation. At $t=0.05$ sec, the distributed energy source is switched on to correct the voltage profile. At 0.25 second, the voltage sag is initiated and the proposed algorithm succeeds to detect the disturbance in less than half of a cycle.

Table 5 Fuel cell distributed generation system parameters.

Fuel Cell Parameters	
Faraday's constant (F)	96484600[C/kmol]
Hydrogen time constant (t_{H_2})	26.1 [sec]
Hydrogen valve molar constant(K_{H_2})	8.43×10^{-4}
k_r Constant= $N_0/4F$	9.9497×10^{-7}
No Load Voltage (E_0)	0.6 [V]
Number of Cells (N_0)	384
Oxygen time constant (t_{O_2})	2.91[sec]
Oxygen valve molar constant (K_{O_2})	2.52×10^{-3}
FC internal resistance (r)	0.126 [Ω]
FC absolute temperature (T)	343 [K]
Universal gas constant (R)	8314.47 [J/(kmol K)]
Utilization Factor (U_p)	0.8
Water time constant (t_{H_2O})	78.3 [sec]
Water valve molar constant (K_{H_2O})	2.81×10^{-4}
DC/DC Converter Parameters	
Rated voltage (V)	200V/540V
Resistance (R)	2.3 [Ω]
Capacitance (C)	1.5 [mf]
Inductor (L)	415 [μ H]
DC/AC Converter Parameters	
Rated Voltage (V)	540V dc/220V ac
Rated Power (W)	100KW
R_s (Ω)	0.9(m Ω)
L_s (H)	0.01(mH)
f_s (Hz)	50(Hz)

Fig. 8 demonstrates that the proposed control structure based Fuzzy Logic Control succeeds in regulating the PCC voltage at 1.0 pu, even when the load disturbance occurs at 0.25s and 0.5s with fast dynamics and minimum overshoot. This result examines the disturbance rejection capabilities of the proposed FLC. It quickly returns the voltage at the PCC to its setting value. Fig. 9(a) indicates that the active power supplied from the DER is almost constant, and is equal to its input command value (1pu) from the control circuit.

Finally, Fig. 9(b) shows the injected reactive power from the distributed energy sources to compensate for the voltage. It is clear from Fig. 9(a) and 9(b) that the control of the active and reactive power is independent of the other. Fig. 10 shows the output voltage changes of fuel cell. As depicted in this Figure, the voltage decreases when the active power increases. The fuel cell voltage has not been affected during the voltage sag. The hydrogen flow rate varies according to the system power requirements as illustrated in Fig. 11.

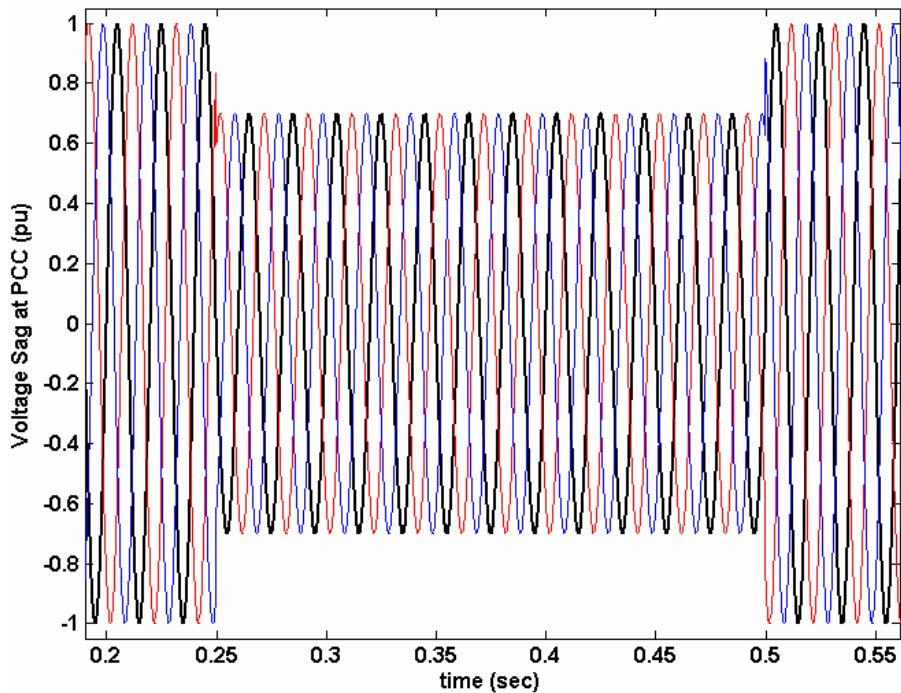

Fig. 7 Three-phase supply voltage during a sag.

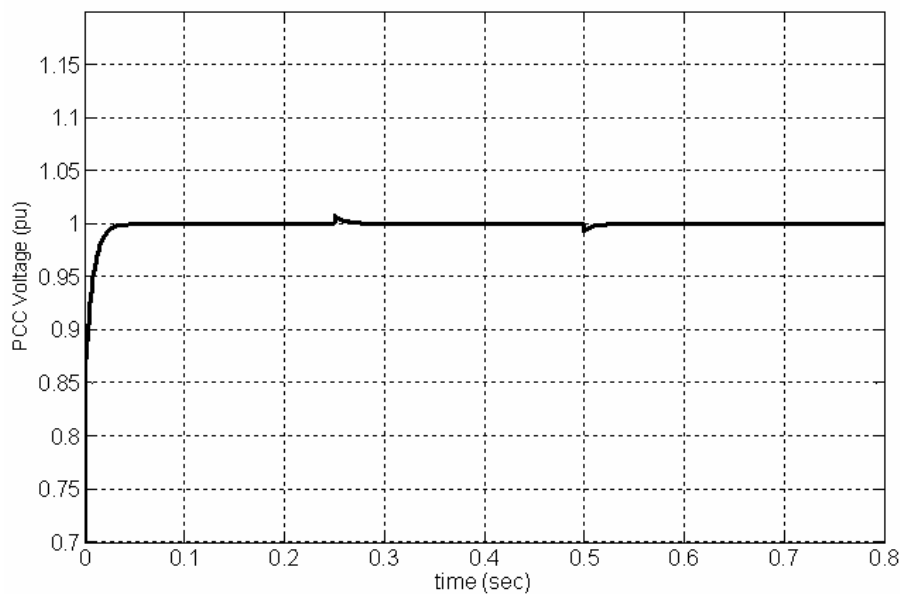

Fig. 8 Regulated Voltage (pu) at PCC.

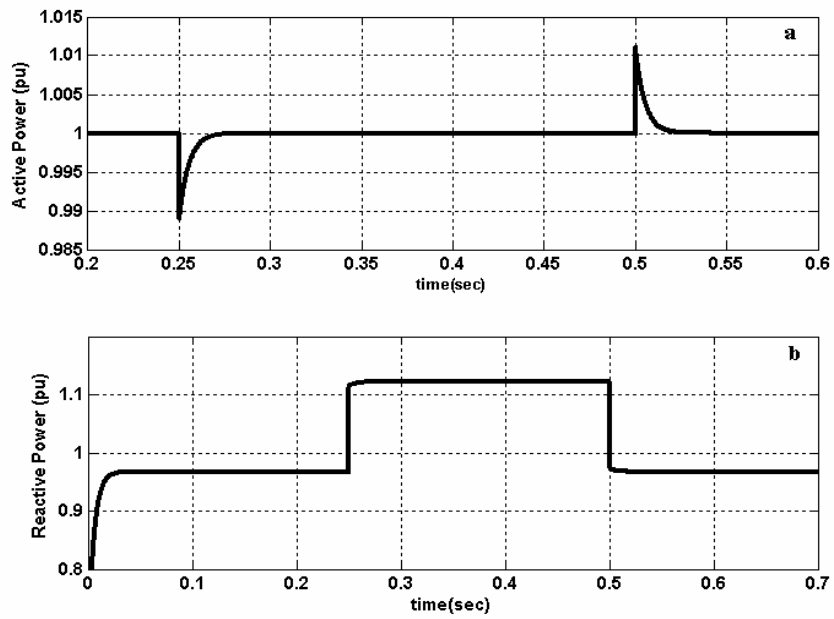

Fig . 9 Produced Active and Reactive Power by FCDG.

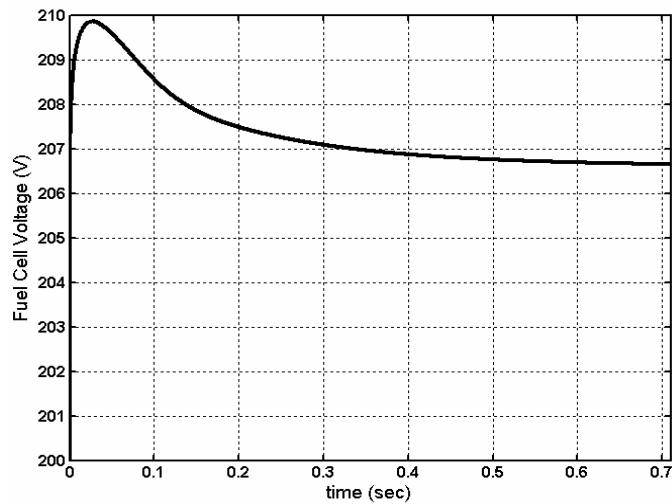

Fig. 10 Variation of Fuel Cell Voltage.

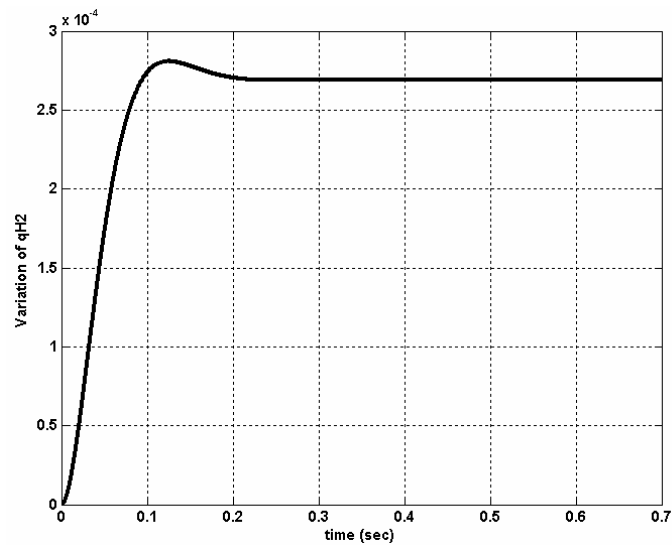

Fig. 11 Variation of hydrogen molar flow.

5 Conclusion

Modeling, control, and simulation study of a SOFC DG system is investigated in this paper. A validated SOFC dynamic model is used to model the fuel cell power plant. The state space models for the boost dc/dc converter and the three-phase inverter are also discussed. Then by designing proper intelligent controllers the capability of FCGD for active power control and voltage disturbance mitigation has been demonstrated. The proposed control method is insensitive to the parameter variation of the distribution system, because it is adaptive in nature. This is an absolute necessity in distribution systems, since there is no dependence on the parameter of the electrical network.

References

- [1] El-Samahy I. and El-Saadany E., "The Effect of DG on Power Quality in a Deregulated Environment," in *Proc. IEEE PES General Meeting*, Jun. 2005.
- [2] Hosseinzadeh Sh., Golkar M. A., Shokri Sh. and Hajizadeh A., "Reliability Improvement and Loss Reduction of Distribution System with Distributed Generation," *International Power System Conference (PSC2006)*, 13-15 Nov. 2006, Tehran-Iran.
- [3] Lee K., "The Effect of DG Using Fuel Cell under Deregulated Electricity Energy Markets," in *Proc. IEEE PES General Meeting*, Jun. 2006.
- [4] Miao Z., Choudhry M. A., Klein K. R. and Fan L., "Study of a fuel cell power plant in power distribution system—Part I: Dynamic model," in *Proc. IEEE PES General Meeting*, Denver, CO, Jun. 2004.
- [5] Hatziaodoniu C. J., Lobo A. A., Pourboghraat F. and Daneshdoost M., "A Simplified Dynamic Model of Grid-Connected Fuel-Cell Generators," *IEEE Transaction on Power Delivery*, Vol. 17, No. 2, APRIL 2002.
- [6] Stevandic S. and Jiang J., "Standalone, Reduced-order Model and Control of a Grid-connected Fuel Cell Power Plant," in *Proc. IEEE PES General Meeting*, July 2003.
- [7] Sedghisigarchi K. and Feliachi A., "Dynamic and Transient Analysis of Power Distribution Systems With Fuel Cells—Part I: Fuel-Cell Dynamic Model," *IEEE Transaction on Energy Conversion*, Vol. 19, No. 2, JUNE 2004.
- [8] Jurado F. and Valverde M., "Fuzzy logic inverter flux control of fuel cell plants in distributed generation," *1th International Conference on Harmonics and Quality of Power*, 2004, Vol. 1, 12-15 Sept. 2004, pp. 35–40.
- [9] Hajizadeh A., Golkar M. A. and Feliachi A., "Power Management Strategy of A Hybrid Distributed Generation System," *International Journal of Distributed Energy Resources*, Vol. 3, No. 2, April-June 2007, ISSN 1614-7138.
- [10] Golkar M. A. and Hajizadeh A., "Fuzzy-Based Mitigation of Voltage Sag and Active Power Control in Distribution System Using Fuel Cell Distributed Generation," *International Power System Conference (PSC2006)*, 13-15 Nov. 2006, Tehran-Iran.
- [11] Padull'es J., Ault G. W. and McDonald J. R., "An integrated SOFC plant dynamic model for power system simulation," *J. Power Sources*, pp. 495–500, 2000.
- [12] Jung J. W. and Keyhani A., "Modeling and Control of Fuel Cell Based Distributed Generation Systems in a Standalone AC Power Supply," *Journal of Iranian Association of Electrical and Electronics Engineers*, Vol. 2, No. 1, Spring and Summer 2005.
- [13] Lee J. H., Lalk T. R. and Appleby A. J., "Modeling electrochemical performance in large scale proton exchange membrane fuel cell stacks," *Journal of Power Sources*, 1998, pp 258-268.
- [14] El-Shater TF., Eskander M. and El-Hagry M., "Hybrid PV/fuel cell system design and simulation," *36th intersociety energy conversion engineering conference*, Savannah, Georgia, July 29–August 2, 2001.
- [15] Yang Z., Shen C., Zhang L., Crow M. L. and Atcitty S., "Integration of a StatCom and Battery Energy Storage," *IEEE Transactions on Power System*, Vol. 16, No. 2, May 2001, pp. 254-260.
- [16] Bollen M. H. J., *Understanding Power Quality Problems: Voltage Sags and Interruptions*. New York IEEE Press, 2000.
- [17] Hajizadeh A. and Golkar M. A., "Voltage Sag Analysis in Distribution Systems," *7th Power System Conference, Power and Water University(PWUT)*, 1-3 Nov. 2006, Tehran-Iran
- [18] Zhu Y. and Tomsovic K., "Development of models for analyzing the load-performance of microturbines and fuel cells," *Electric Power System Research*, 62 (2002) 1-11.



Amin Hajizadeh was born in Ferdows, Iran in 1980. He received his B.Sc. degree from Mashad University, Mashad-Iran in 2002, M.Sc degree from the K.N.Toosi University of technology Tehran-Iran in 2005, all in Electrical Engineering (Control and Power Systems). He is currently pursuing the Ph.D. degree at the K.N.Toosi University of technology Tehran-

Iran. His current research interest includes intelligent control of distributed energy resources and optimization of hybrid power systems and distributed generation.



Masoud AliAkbar-Golkar was born in Tehran Iran in 1954. He received his B.Sc. degree from Sharif University of Technology Tehran-Iran in 1977, M.Sc. from The Oklahoma State University USA in 1979 and his Ph.D. degree from the Imperial College of Science, Technology, and Medicine (The University of London, UK) in 1986, all in Electrical Engineering (Power Systems). His employment

experience included working as an Associate Professor at the K N Toosi University, Tehran, Advisor to Tehran Electricity Board, Head of research group at Electric Power Research Center in Tehran .Now he is an Associate Professor at K N Toosi University of Technology in Tehran, Iran.